



MPFILTRI[®]

PASSION TO PERFORM



A WORLDWIDE LEADER IN THE FIELD
OF HYDRAULIC FILTRATION EQUIPMENT.

Our company started life in 1964, when Bruno Pasotto decided to attempt to cater for the requests of a market still to be fully explored, with the study, design, development, production and marketing of a vast range of filters for hydraulic equipment, capable of satisfying the needs of manufacturers in all sectors. The quality of our products, our extreme competitiveness compared with major international producers and our constant activities of research, design and development has made us a worldwide leader in the field of hydraulic circuit filtering. Present for over 50 years in the market, we have played a truly decisive role in defining our sector, and by now we are a group capable of controlling our entire chain of production, monitoring all manufacturing processes to guarantee superior quality standards and to provide concrete solutions for the rapidly evolving needs of customers and the market.

CONTAMINATION CONTROL SOLUTIONS



...because contamination costs!

1 page INTRODUCTION

4	COMPANY PROFILE
8	PRODUCT RANGE
11	CONTAMINATION MANAGEMENT

18 page CONTAMINATION MONITORING PRODUCTS

21	LPA3	Portable Light Extinction Particle Analyser
27	LPA2 Aviation Edition	Portable Twin-laser Particle Analyser
33	CML3	Compact Portable Contamination Monitor
39	CML4	Compact Portable Contamination Monitor
45	ICM 4.0	Wifi-enabled In-line Contamination Monitor
51	ICM 2.0	In-line Contamination Monitor
57	ICM K 2.0 AZ2	ATEX Inline Contamination Monitor
63	ICS	In-line Contamination Sensor
69	ICU	In-line Contamination Monitoring Unit
75	ACMU	Auxiliary Contamination Monitoring Unit
83	BS110 & BS500	Bottle Samplers
92	HOW SAMPLING	
95	PATCH IMAGING KIT	Patch Sampling and Digital Imaging Kit
99	FLUID COMPATIBILITY CHARTS	

100 page MOBILE FILTRATION UNITS

103	UFM 015	Mobile filtration unit 15 l/min flow rate
113	UFM 041	Mobile filtration unit 34 l/min flow rate
119	UFM 051	Mobile filtration unit 50 l/min flow rate
125	UFM 091	Mobile filtration unit 90 l/min flow rate
131	UFM 181	Mobile filtration unit 180 l/min flow rate
137	UFM 919	Mobile filtration unit 90 l/min and 180 l/min flow rate
143	FTU	Fluid transfer unit 15 l/min flow rate, with ICM 2.0 / 4.0 (In-line Contamination Monitor)

Our work is based on a skillful interaction between advanced technology and fine workmanship, **customizing products according to specific market requests**, focusing strongly on innovation and quality, and following every step in the manufacturing of both standard and special products, fully respecting customer expectations.

MARKET LEADER



Our customer-oriented philosophy, which enables us to satisfy all customer requests **rapidly** and **with personalized products**, makes us a **dynamic and flexible enterprise**.

The possibility of constantly controlling and monitoring the entire production process is essential to allow us to guarantee the quality of our products.

WORLDWIDE PRESENCE



Scan or click me!

Our foreign Branches enable us to offer a diversified range of products that allow us to successfully face the aggressive challenge of international competition, and also to maintain a stable presence at a local level.

The Group boasts **9** business branches



TECHNOLOGY

Our constant **quest for excellence in quality and technological innovation** allows us to offer only the best solutions and services for applications in many fields, including general industry, test rigs, lubrication, heavy engineering, renewable energies, naval engineering, offshore engineering, aviation systems, emerging technologies and mobile plant (i.e. tractors, excavators, concrete pumps, platforms).



AND PRODUCTION

Our high level of technological expertise means **we can rely entirely on our own resources, without resorting to external providers.** This in turn enables us to satisfy a growing number of customer requests, also exploiting our constantly updated range of machines and equipment, featuring **fully-automated workstations** capable of **24-hour production.**

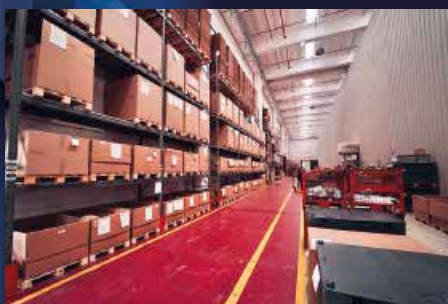



SUCTION FILTERS

- Mounting:
- Tank immersed
 - In-Line
 - In tank with shut off valve
 - In tank with flooded suction



RETURN FILTERS

- Mounting:
- In-Line
 - Tank top
 - In single and duplex designs



RETURN / SUCTION FILTERS

- Mounting:
- In-Line
 - Tank top



SPIN-ON FILTERS

- Mounting:
- In-Line
 - Tank top



LOW & MEDIUM PRESSURE FILTERS

- Mounting:
- In-Line
 - Parallel manifold version
 - In single and duplex designs



HIGH PRESSURE FILTERS

- Mounting:
- In-Line
 - Manifold
 - In single and duplex designs

PRODUCT RANGE

MP Filtri can offer a vast and articulated range of products for the global market, suitable for all industrial sectors using hydraulic equipment.

This includes filters (suction, return, return/suction, spin-on, pressure, stainless steel pressure, ATEX filters) and structural components (motor/pump bell-housings, transmission couplings, damping rings, foot brackets, aluminium tanks, cleaning covers).

We can provide all the skills and solutions required by the modern hydraulics industry to monitor contamination levels and other fluid conditions.

Mobile filtration units and a full range of accessories allow us to supply everything necessary for a complete service in the hydraulic circuits.



STAINLESS STEEL HIGH PRESSURE FILTERS

- Mounting:
- In-Line
 - Manifold
 - In single and duplex designs

FILTERS FOR POTENTIALLY EXPLOSIVE ATMOSPHERE

- Mounting:
- In-Line

CONTAMINATION CONTROL SOLUTIONS

- Off-line, in-line particle analyser
- Off-line bottle sampling products
- Fully calibrated using relevant ISO standards
- A wide range of variants to support fluid types and communication protocols
- Mobile Filtration Units with flow rates from 15 l/min up to 200 l/min

POWER TRANSMISSION PRODUCTS

- Aluminium bell-housings for motors from 0.12 kW to 400 kW
- Couplings in Aluminium Cast Iron - Steel
- Damping rings
- Foot bracket
- Aluminium tanks
- Cleaning covers

TANK ACCESSORIES

- Oil filler and air breather plugs
- Optical and electrical level gauges
- Pressure gauge valve selectors
- Pipe fixing brackets
- Pressure gauges

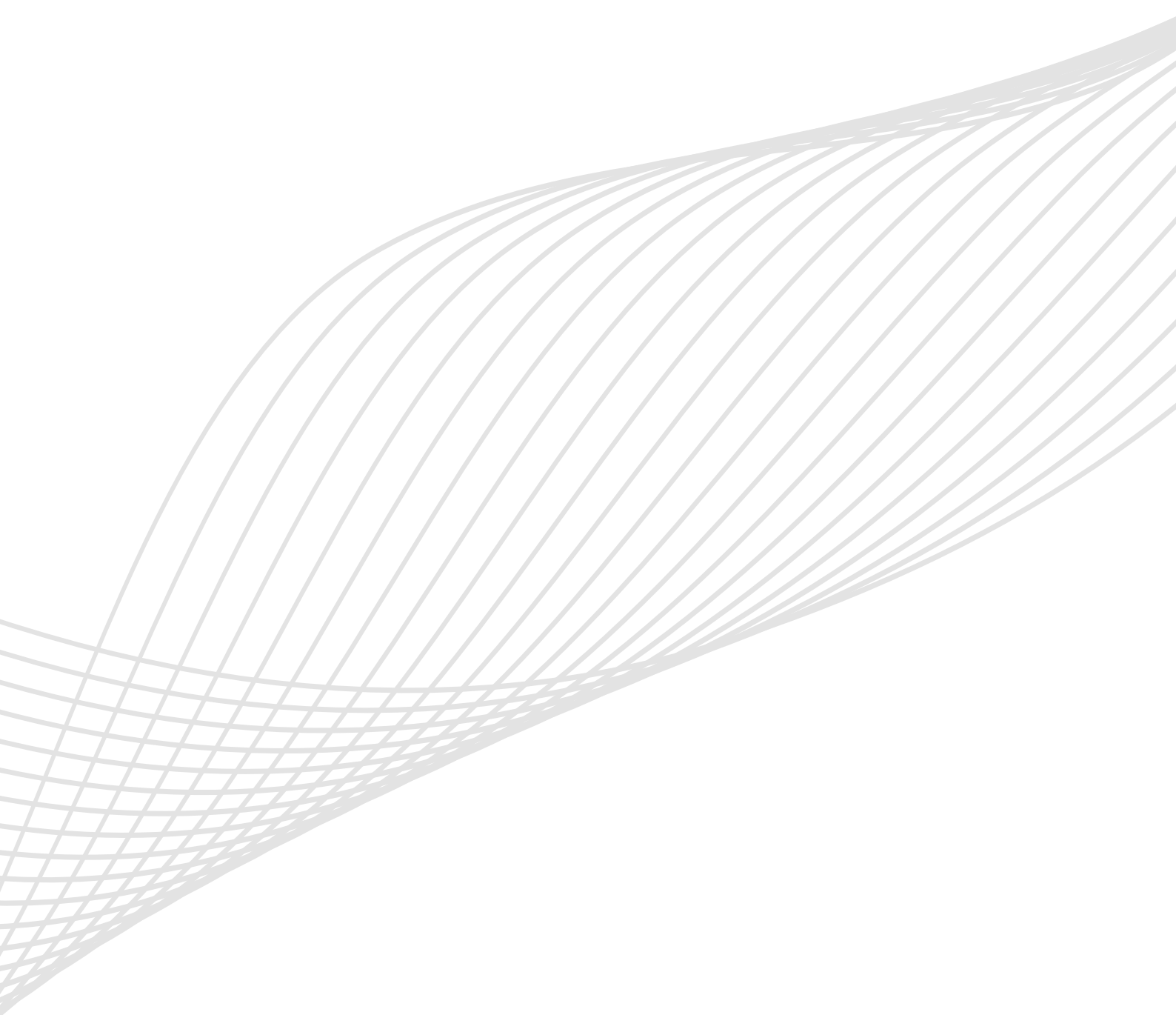

Contamination management

INDEX

	Page
① HYDRAULIC FLUIDS	12
② FLUIDS CONTAMINATION	12
③ FLUIDS COMPATIBILITY CHART	12
④ EFFECTS OF CONTAMINATION ON HYDRAULIC COMPONENTS	13
⑤ MEASURING THE SOLID CONTAMINATION LEVEL	13
⑥ FILTRATION TECHNOLOGIES	16
⑦ APPLICABLE STANDARDS FOR FILTER DEVELOPMENT	17

1 HYDRAULIC FLUIDS

The fluid is the vector that transmits power, energy within an oleodynamic circuit. In addition to transmitting energy through the circuit, it also performs additional functions such as lubrication, protection and cooling of the surfaces.

The classification of fluids used in hydraulic systems is coded in many regulatory references, different Standards.

The most important classification system for hydraulic fluids is the one defined by International Organization for Standardization (ISO), which established a classification system within their standard: "ISO 6743-4 Lubricants, Industrial Oils and Related Products". In particular, the parts of interest for hydraulic fluids are:

- Lubricants, industrial oils and related products (class L)
- Classifications - Part 4L - Family H (Hydraulic systems)

The ISO 6743-4 classification system can be generally applied to the three primary classes of hydraulic fluids:

- Mineral Oils (i.e.: petroleum) Hydraulic Fluids (i.e.: HH: Mineral lubricants without corrosion inhibitors; HL: HH-type lubricants with oxidation reduction and anticorrosive additives; HM: HL-type lubricants with anti-wear additives; HV: HM-type lubricants with a higher viscosity grade and temperature properties; and others).
- Biodegradable Hydraulic Fluids (HExx), also defined as "Environmentally acceptable hydraulic fluids".
- Fire Resistant Hydraulic Fluids (HFxx), which could be further split into: Fire-resistant aqueous fluids (HFAx, HFB; HFC) ; Fire-resistant synthetic anhydrous fluids (HFDx).

The choice of fluid for an hydraulic system must take into account several parameters.

These parameters can adversely affect the performance of an hydraulic system, causing delay in the controls, pump cavitation, excessive absorption, excessive temperature rise, efficiency reduction, increased drainage, wear, jam/block or air intake in the plant.

The main properties that characterize hydraulic fluids and affect their choice are:

- **DYNAMIC VISCOSITY**
It identifies the fluid's resistance to sliding due to the impact of the particles forming it.
- **KINEMATIC VISCOSITY**
It is a widespread formal dimension in the hydraulic field.
It is calculated with the ratio between the dynamic viscosity and the fluid density.
Kinematic viscosity varies with temperature and pressure variations.
- **VISCOSITY INDEX**
This value expresses the ability of a fluid to maintain viscosity when the temperature changes.
A high viscosity index indicates the fluid's ability to limit viscosity variations by varying the temperature.
- **FILTERABILITY INDEX**
It is the value that indicates the ability of a fluid to cross the filter materials.
A low filterability index could cause premature clogging of the filter material.
- **WORKING TEMPERATURE**
Working temperature affects the fundamental characteristics of the fluid.
As already seen, some fluid characteristics, such as cinematic viscosity, vary with the temperature variation.

When choosing a hydraulic oil, must therefore be taken into account of the environmental conditions in which the machine will operate.

- **COMPRESSIBILITY MODULE**
Every fluid subjected to a pressure contracts, increasing its density.
The compressibility module identifies the increase in pressure required to cause a corresponding increase in density.
- **HYDROLYTIC STABILITY**
It is the characteristic that prevents galvanic pairs that can cause wear in the plant/system.
- **ANTIOXIDANT STABILITY AND WEAR PROTECTION**
These features translate into the capacity of a hydraulic oil to avoid corrosion of metal elements inside the system.
- **HEAT TRANSFER CAPACITY**
It is the characteristic that indicates the capacity of hydraulic oil to exchange heat with the surfaces and then cool them.

2 FLUID CONTAMINATION

Whatever the nature and properties of fluids, they are inevitably subject to contamination. Fluid contamination can have two origins:

- **INITIAL CONTAMINATION**
Caused by the introduction of contaminated fluid into the circuit, or by incorrect storage, transport or transfer operations.
- **PROGRESSIVE CONTAMINATION**
Caused by factors related to the operation of the system, such as metal surface wear, sealing wear, oxidation or degradation of the fluid, the introduction of contaminants during maintenance, corrosion due to chemical or electrochemical action between fluid and components, cavitation.
The contamination of hydraulic systems can be of different nature:
- **SOLID CONTAMINATION**
For example rust, slag, metal particles, fibers, rubber particles, paint particles or additives
- **LIQUID CONTAMINATION**
For example, the presence of water due to condensation or external infiltration or acids
- **GASEOUS CONTAMINATION**
For example, the presence of air due to inadequate oil level in the tank, drainage in suction ducts, incorrect sizing of tubes or tanks.

3 FLUID COMPATIBILITY CHARTS

For more detailed information on specific fluid compatibility please refer to the fluid compatibility charts on our website:



Scan or click me!

④ EFFECTS OF CONTAMINATION ON HYDRAULIC COMPONENTS

Solid contamination is recognized as the main cause of malfunction, failure and early degradation in hydraulic systems. It is impossible to delete it completely, but it can be effectively controlled by appropriate devices.

CONTAMINATION IN PRESENCE OF LARGE TOLERANCES



CONTAMINATION IN PRESENCE OF NARROW TOLERANCES



Solid contamination mainly causes surface damage and component wear.

- ABRASION OF SURFACES
Cause of leakage through mechanical seals, reduction of system performance, failures.
- SURFACE EROSION
Cause of leakage through mechanical seals, reduction of system performance, variation in adjustment of control components, failures.
- ADHESION OF MOVING PARTS
Cause of failure due to lack of lubrication.
- DAMAGES DUE TO FATIGUE
Cause of breakdowns and components breakdown.

ABRASION



EROSION



ADHESION

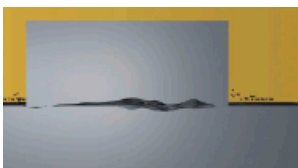

FATIGUE



Liquid contamination mainly results in decay of lubrication performance and protection of fluid surfaces.

DISSOLVED WATER

- INCREASING FLUID ACIDITY
Cause of surface corrosion and premature fluid oxidation
- GALVANIC COUPLE AT HIGH TEMPERATURES
Cause of corrosion

FREE WATER - ADDITIONAL EFFECTS

- DECAY OF LUBRICANT PERFORMANCE
Cause of rust and sludge formation, metal corrosion and increased solid contamination
- BATTERY COLONY CREATION
Cause of worsening in the filterability feature

- ICE CREATION AT LOW TEMPERATURES
Cause damage to the surface
- ADDITIVE DEPLETION
Free water retains polar additives

Gaseous contamination mainly results in decay of system performance.

- CUSHION SUSPENSION
Cause of increased noise and cavitation.
- FLUID OXIDATION
Cause of corrosion acceleration of metal parts.
- MODIFICATION OF FLUID PROPERTIES (COMPRESSIBILITY MODULE, DENSITY, VISCOSITY)
Cause of system's reduction of efficiency and of control. It is easy to understand how a system without proper contamination management is subject to higher costs than a system that is provided.
- MAINTENANCE
Increase maintenance activities, spare parts, machine stop costs.
- ENERGY AND EFFICIENCY
Efficiency and performance reduction due to friction, drainage, cavitation.

⑤ MEASURING THE SOLID CONTAMINATION LEVEL

The level of contamination of a system identifies the amount of contaminant contained in a fluid. This parameter refers to a unit volume of fluid. The level of contamination may be different at different points in the system. From the information in the previous paragraphs it is also apparent that the level of contamination is heavily influenced by the working conditions of the system, by its working years and by the environmental conditions.

What is the size of the contaminating particles that we must handle in our hydraulic circuit?

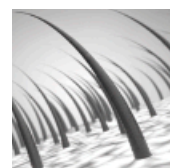

HUMAN HAIR
(75 µm)

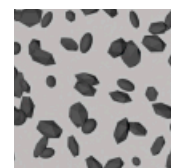

MINIMUM DIMENSION
VISIBLE WITH HUMAN
EYES
(40 µm)

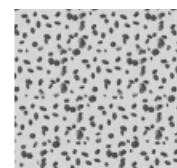

TYPICAL CONTAMINANT
DIMENSION IN A
HYDRAULIC CIRCUIT
(4 - 14 µm)

Contamination level analysis is significant only if performed with a uniform and repeatable method, conducted with standard test methods and suitably calibrated equipment. To this end, ISO has issued a set of standards that allow tests to be conducted and express the measured values in the following ways.

- GRAVIMETRIC LEVEL - ISO 4405

The level of contamination is defined by checking the weight of particles collected by a laboratory membrane. The membrane must be cleaned, dried and desiccated, with fluid and conditions defined by the Standard. The volume of fluid is filtered through the membrane by using a suitable suction system. The weight of the contaminant is determined by checking the weight of the membrane before and after the fluid filtration.



CLEAN
MEMBRANE

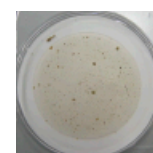

CONTAMINATED
MEMBRANE

CONTAMINATION MANAGEMENT

- CUMULATIVE DISTRIBUTION OF THE PARTICLES SIZE - ISO 4406

The level of contamination is defined by counting the number of particles of certain dimensions per unit of volume of fluid. Measurement is performed by Contamination Monitoring Products (CMP).

Following the count, the contamination classes are determined, corresponding to the number of particles detected in the unit of fluid.

The most common classification methods follow ISO 4406 and SAE AS 4059 (Aerospace Sector) regulations.

NAS 1638 is still used although obsolete.

Classification example according to ISO 4406

The International Standards Organization standard ISO 4406 is the preferred method of quoting the number of solid contaminant particles in a sample. The level of contamination is defined by counting the number of particles of certain dimensions per unit of volume of fluid. The measurement is performed by Contamination Monitoring Products (CMP).

The numbers represent a code which identifies the number of particles of certain sizes in 1ml of fluid. Each code number has a particular size range. The first scale number represents the number of particles equal to or larger than 4 $\mu\text{m}_{(c)}$ per millilitre of fluid; The second scale number represents the number of particles equal to or larger than 6 $\mu\text{m}_{(c)}$ per millilitre of fluid; The third scale number represents the number of particles equal to or larger than 14 $\mu\text{m}_{(c)}$ per millilitre of fluid.

ISO 4406 - Allocation of Scale Numbers

Class	Number of particles per ml	
	Over	Up to
28	1 300 000	2 500 000
27	640 000	1 300 000
26	320 000	640 000
25	160 000	320 000
24	80 000	160 000
23	40 000	80 000
22	20 000	40 000
21	10 000	20 000
20	5 000	10 000
19	2 500	5 000
18	1 300	2 500
17	640	1 300
16	320	640
15	160	320
14	80	160
13	40	80
12	20	40
11	10	20
10	5	10
9	2.5	5
8	1.3	2.5
7	0.64	1.3
6	0.32	0.64
5	0.16	0.32
4	0.08	0.16
3	0.04	0.08
2	0.02	0.04
1	0.01	0.02
0	0	0.01

- > 4 $\mu\text{m}_{(c)}$ = 350 particles
 - > 6 $\mu\text{m}_{(c)}$ = 100 particles
 - > 14 $\mu\text{m}_{(c)}$ = 25 particles
- 16 / 14 / 12

ISO 4406 Cleanliness Code System

Microscope counting examines the particles differently to Contamination Monitoring Products (CMP) and the code is given with two scale numbers only. These are at 5 μm and 15 μm equivalent to the 6 $\mu\text{m}_{(c)}$ and 14 $\mu\text{m}_{(c)}$ of Contamination Monitoring Products (CMP).

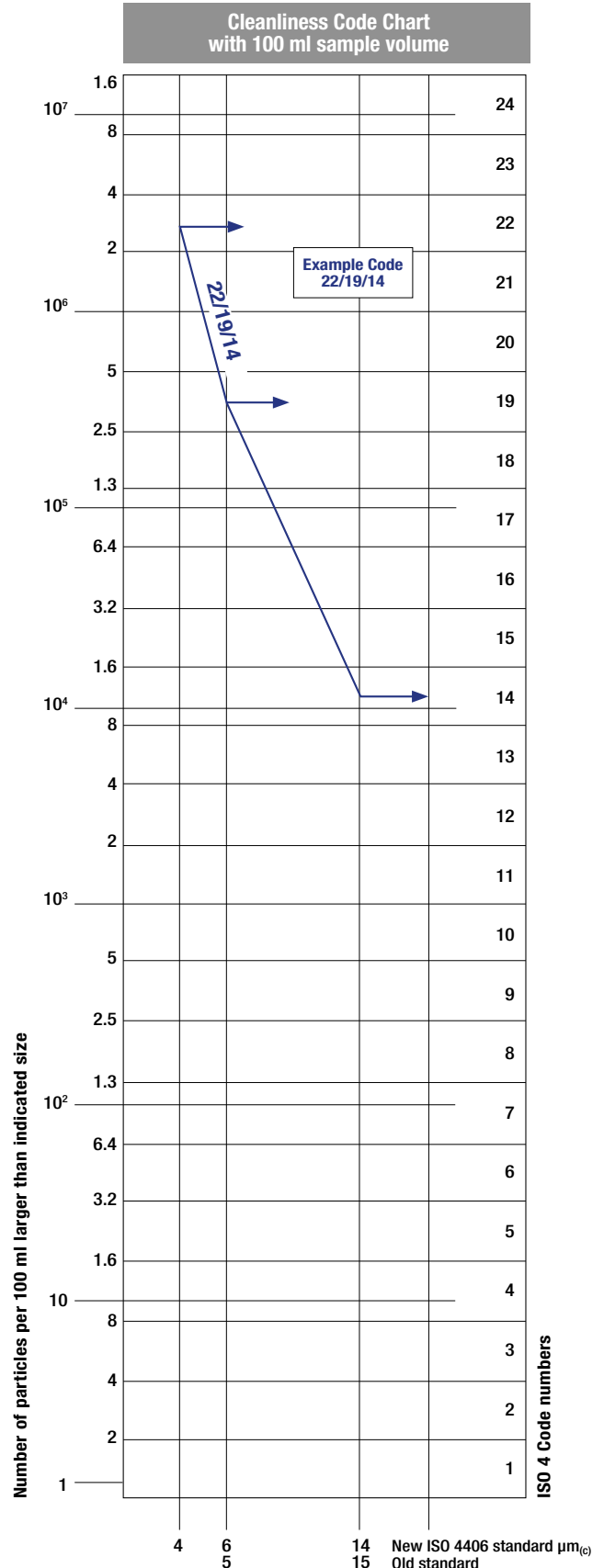

- CUMULATIVE DISTRIBUTION OF THE PARTICLES SIZE
SAE AS4059-1 and SAE AS4059-2

Classification example according to SAE AS4059 - Rev. G

The code, prepared for the aerospace industry, is based on the size, quantity, and particle spacing in a 100 ml fluid sample. The contamination classes are defined by numeric codes, the size of the contaminant is identified by letters (A-F).

This SAE Aerospace Standard (AS) defines cleanliness levels for particulate contamination of hydraulic fluids and includes methods of reporting data relating to the contamination levels. Tables 1 and 2 below provide differential and cumulative particle counts respectively for counts obtained by an automatic particle counter, e.g. LPA3.

Table 1 - Class for differential measurement

Class	Dimension of contaminant Maximum Contamination Limits per 100 ml (3)				
	5-15 µm	15-25 µm	25-50 µm	50-100 µm	>100 µm (1)
	6-14 µm(c)	14-21 µm(c)	21-38 µm(c)	38-70 µm(c)	>70 µm(c) (2)
00	125	22	4	1	0
0	250	44	8	2	0
1	500	89	16	3	1
2	1 000	178	32	6	1
3	2 000	356	63	11	2
4	4 000	712	126	22	4
5	8 000	1 425	253	45	8
6	16 000	2 850	506	90	16
7	32 000	5 700	1 012	180	32
8	64 000	11 400	2 025	360	64
9	128 000	22 800	4 050	720	128
10	256 000	45 600	8 100	1 440	256
11	512 000	91 200	16 200	2 880	512
12	1 024 000	182 400	32 400	5 760	1 024

6 - 14 µm(c) = 15 000 particles
14 - 21 µm(c) = 2 200 particles
21 - 38 µm(c) = 200 particles
38 - 70 µm(c) = 35 particles
> 70 µm(c) = 3 particles
SAE AS4059 REV G - Class 6

(1) Size range, optical microscope, based on longest dimension as measured per AS598 or ISO 4407. (2) Size range CMP calibrated per ISO 11171 or an optical or electron microscope with image analysis software, based on projected area equivalent diameter. (3) Contamination classes and particle count limits are identical to NAS 1638.

Table 2 - Class for cumulative measurement

Class	Dimension of contaminant Maximum Contamination Limits per 100 ml					
	>1 µm	>5 µm	>15 µm	>25 µm	>50 µm	>100 µm (1)
	>4 µm(c)	>6 µm(c)	>14 µm(c)	>21 µm(c)	>38 µm(c)	>70 µm(c) (2)
000	195	76	14	3	1	0
00	390	152	27	5	1	0
0	780	304	54	10	2	0
1	1 560	609	109	20	4	1
2	3 120	1 217	217	39	7	1
3	6 250	2 432	432	76	13	2
4	12 500	4 864	864	152	26	4
5	25 000	9 731	1 731	306	53	8
6	50 000	19 462	3 462	612	106	16
7	100 000	38 924	6 924	1 224	212	32
8	200 000	77 849	13 849	2 449	424	64
9	400 000	155 698	27 698	4 898	848	128
10	800 000	311 396	55 396	9 796	1 696	256
11	1 600 000	622 792	110 792	19 592	3 392	512
12	3 200 000	1 245 584	221 584	39 184	6 784	1 024

> 4 µm(c) = 45 000 particles
> 6 µm(c) = 15 000 particles
> 14 µm(c) = 1 500 particles
> 21 µm(c) = 250 particles
> 38 µm(c) = 15 particles
> 70 µm(c) = 3 particles
SAE AS4059 REV G cpc* Class 6 6/6/5/5/4/2

* cumulative particle count

(1) Size range, optical microscope, based on longest dimension as measured per AS598 or ISO 4407. (2) Size range, CMP calibrated per ISO 11171 or an optical or electron microscope with image analysis software, based on projected area equivalent diameter. (3) Contamination classes and particle count limits are identical to NAS 1638.

- CLASSES OF CONTAMINATION ACCORDING TO NAS 1638 (January 1964)

The NAS system was originally developed in 1964 to define contamination classes for the contamination contained within aircraft components.

The application of this standard was extended to industrial hydraulic systems simply because nothing else existed at the time.

The coding system defines the maximum numbers permitted of 100 ml volume at various size intervals (differential counts) rather than using cumulative counts as in ISO 4406. Although there is no guidance given in the standard on how to quote the levels, most industrial users quote a single code which is the highest recorded in all sizes and this convention is used on MP Filtri Contamination Monitoring Products (CMP).

The contamination classes are defined by a number (from 00 to 12) which indicates the maximum number of particles per 100 ml, counted on a differential basis, in a given size bracket.

Size Range Classes (in microns)

Class	Maximum Contamination Limits per 100 ml				
	5-15	15-25	25-50	50-100	>100
	5-15 µm	15-25 µm	25-50 µm	50-100 µm	>100 µm
00	125	22	4	1	0
0	250	44	8	2	0
1	500	89	16	3	1
2	1 000	178	32	6	1
3	2 000	356	63	11	2
4	4 000	712	126	22	4
5	8 000	1 425	253	45	8
6	16 000	2 850	506	90	16
7	32 000	5 700	1 012	180	32
8	64 000	11 400	2 025	360	64
9	128 000	22 800	4 050	720	128
10	256 000	45 600	8 100	1 440	256
11	512 000	91 200	16 200	2 880	512
12	1 024 000	182 400	32 400	5 760	1 024

5-15 µm = 42 000 particles
15-25 µm = 2 200 particles
25-50 µm = 150 particles
50-100 µm = 18 particles
> 100 µm = 3 particles
Class NAS 8

- CUMULATIVE DISTRIBUTION OF THE PARTICLES SIZE - ISO 4407

The level of contamination is defined by counting the number of particles collected by a laboratory membrane per unit of fluid volume. The measurement is done by a microscope. The membrane must be cleaned, dried and desiccated, with fluid and conditions defined by the Standard. The fluid volume is filtered through the membrane, using a suitable suction system.

The level of contamination is identified by dividing the membrane into a predefined number of areas and by counting the contaminant particles using a suitable laboratory microscope.

MICROSCOPE CONTROL AND MEASUREMENT



Example figure 1 and 2

COMPARISON PHOTOGRAPH'S
1 graduation = 10µm



Fig. 1



Fig. 2



Scan or click me!

For other comparison photographs for contamination classes see the "Filtration and Particle Analyser Handbook".

- CLEANLINESS CODE COMPARISON

Although ISO 4406 standard is being used extensively within the hydraulics industry other standards are occasionally required and a comparison may be requested. The table below gives a very general comparison but often no direct comparison is possible due to the different classes and sizes involved.

ISO 4406	SAE AS4059 Table 2	SAE AS4059 Table 1	NAS 1638
> 4 $\mu\text{m}_{(c)}$ 6 $\mu\text{m}_{(c)}$ 14 $\mu\text{m}_{(c)}$	> 4 $\mu\text{m}_{(c)}$ 6 $\mu\text{m}_{(c)}$ 14 $\mu\text{m}_{(c)}$	4-6 6-14 14-21 21-38 38-70 >70	5-15 15-25 25-50 50-100 >100
23 / 21 / 18	13A / 12B / 12C	12	12
22 / 20 / 17	12A / 11B / 11C	11	11
21 / 19 / 16	11A / 10B / 10C	10	10
20 / 18 / 15	10A / 9B / 9B	9	9
19 / 17 / 14	9A / 8B / 8C	8	8
18 / 16 / 13	8A / 7B / 7C	7	7
17 / 15 / 12	7A / 6B / 6C	6	6
16 / 14 / 11	6A / 5B / 5C	5	5
15 / 13 / 10	5A / 4B / 4C	4	4
14 / 12 / 09	4A / 3B / 3C	3	3

6 FILTRATION TECHNOLOGIES

Various mechanisms such as mechanical stoppage, magnetism, gravimetric deposit, or centrifugal separation can be used to reduce the level of contamination.

The mechanical stoppage method is most effective and can take place in two ways:

- SURFACE FILTRATION

It is by direct interception. The filter prevents particles larger than the pores from continuing in the plant / system. Surface filters are generally manufactured with metal canvases or meshes.

- DEPTH FILTERING

Filters are constructed by fiber interlacing. Such wraps form pathways of different shapes and sizes in which the particles remain trapped when they find smaller apertures than their diameter.

Depth filters are generally produced with papers impregnated with phenolic resins, metal fibers or inorganic fibers.

In inorganic fiber filtration, commonly called microfibre, the filtering layers are often overlapped in order to increase the ability to retain the contaminant.

WIRE MESH FILTRATION

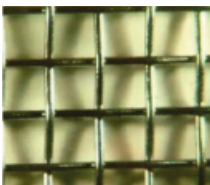

PAPER FILTRATION



MICROFIBER FILTRATION

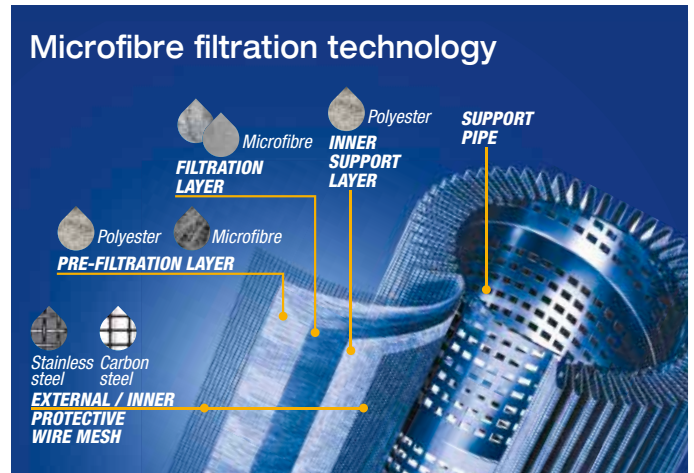
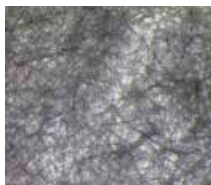

The filtration efficiency of metallic mesh filtrations is defined as the maximum particle size that can pass through the meshes of the filtering grid.

The efficiency of microfibre and paper filtration ($\beta_{x(c)}$) is defined through a lab test called Multipass Test. The efficiency value ($\beta_{x(c)}$) is defined as the ratio between the number of particles of certain dimensions detected upstream and downstream of the filter.

$$\frac{\text{Upstream particles number} > X \mu\text{m}_{(c)}}{\text{Downstream particles number} > X \mu\text{m}_{(c)}} = \beta_{x(c)}$$



Value ($\beta_{x(c)}$)	2	10	75	100	200	1000
Efficiency	50%	90%	98.7%	99%	99.5%	99.9%

Test conditions, such as type of fluid to be used (MIL-H-5606), type of contaminant to be used (ISO MTD), fluid viscosity, test temperature, are determined by ISO 16889.

In addition to the filtration efficiency value during the Multipass test, other important features, such as filtration stability (β stability) and dirt holding capacity (DHC), are also tested.

Poor filtration stability is the cause of the filtering quality worsening as the filter life rises. Low dirt holding capacity causes a reduction in the life of the filter.

Filtration ISO Standard Comparison

$\beta_{x(c)} > 1000$ ISO 16889	$\beta_x > 200$ ISO 4572	MP Filtri Filter media code
5 $\mu\text{m}_{(c)}$	3 μm	A (00) 03
7 $\mu\text{m}_{(c)}$	6 μm	A (00) 06
10 $\mu\text{m}_{(c)}$	10 μm	A (00) 10
16 $\mu\text{m}_{(c)}$	18 μm	A (00) 16
21 $\mu\text{m}_{(c)}$	25 μm	A (00) 25

7 APPLICABLE STANDARDS FOR FILTER DEVELOPMENT

In order to obtain unique criteria for development and verification of the filters performance, specific regulations for the filters and filter elements testing have been issued by ISO. These norms describe the target, the methodology, the conditions and the presentation methods for the test results.

ISO 2941

Hydraulic fluid power -- Filter elements -- Verification of collapse/burst pressure rating

This Standard describes the method for testing the collapse / burst resistance of the filter elements.

The test is performed by crossing the contaminated fluid filter element at a predefined flow rate. The progressive clogging of the filter element, determined by contamination, causes an increase in differential pressure.

ISO 2942

Hydraulic fluid power -- Filter elements -- Verification of fabrication integrity and determination of the first bubble point

This Standard describes the method to verify the integrity of the assembled filter elements.

It can be used to verify the quality of the production process or the quality of the materials by verifying the pressure value of the first bubble point.

ISO 2943

Hydraulic fluid power -- Filter elements -- Verification of material compatibility with fluids

This Standard describes the method to verify the compatibility of materials with certain hydraulic fluids.

The test is carried out by keeping the element (the material sample) immersed in the fluid under high or low temperature conditions for a given period of time and verifying the retention of the characteristics.

ISO 3723

Hydraulic fluid power -- Filter elements -- Method for end load test

This Standard describes the method for verifying the axial load resistance of the filter elements.

After performing the procedure described in ISO 2943, the designed axial load is applied to the filter element. To verify the test results, then the test described in ISO 2941 is performed.

ISO 3968

Hydraulic fluid power -- Filters -- Evaluation of differential pressure versus flow characteristics

This Standard describes the method for checking the pressure drop across the filter.

The test is carried out by crossing the filter from a given fluid and by detecting upstream and downstream pressures.

Some of the parameters defined by the Standard are the fluid, the test temperature, the size of the tubes, the position of the pressure detection points.

ISO 16889

Hydraulic fluid power -- Filters -- Multi-pass method for evaluating filtration performance of a filter element

This Standard describes the method to check the filtration characteristics of the filter elements.

The test is performed by constant introduction of contaminant (ISO MTD). The characteristics observed during the test are the filtration efficiency and the dirty holding capacity related to the differential pressure.

ISO 23181

Hydraulic fluid power -- Filter elements -- Determination of resistance to flow fatigue using high viscosity fluid

This Standard describes the method for testing the fatigue resistance of the filter elements. The test is carried out by subjecting the filter to continuous flow variations, thus differential pressure, using a high viscosity fluid.

ISO 11170

Hydraulic fluid power -- Sequence of tests for verifying performance characteristics of filter elements

The Standard describes the method for testing the performance of filter elements. The protocol described by the regulations provides the sequence of all the tests described above in order to verify all the working characteristics (mechanical, hydraulic and filtration).

ISO 10771-1

Hydraulic fluid power -- Fatigue pressure testing of metal pressure-containing envelopes -- Test method

This Standard describes the method to check the resistance of the hydraulic components with pulsing pressure.

It can be applied to all metal components (excluding tubes) subject to cyclic pressure used in the hydraulic field.

You can see right through our results

It's no secret the presence of particles in the hydraulic fluid is the primary cause of failure, unreliability and short component life in hydraulic systems - whether they be fluid power, lubrication or fuel. We have developed an extensive range of products to help you safeguard your machines and systems from potential failure.

Benefits:

- **Promptly measures and maintains the appropriate fluid cleanliness level**
- **Damages and downtime are minimised, reducing costs**
- **Provides a maintenance regime to immediately respond to an incident**

Applications:

- **Industrial hydraulic and lubrication systems**
- **Mobile hydraulics**
- **Aerospace and offshore applications**

Contamination Monitoring Products (CMP)

CMP Portable online products



LPA3



LPA2
Aviation
Edition



CML3



CML4

Inline Contamination Monitors



ICM 4.0



ICM 2.0



ICMK2.0 AZ2



ICS



ICU



ACMU

Offline products



BS110 & BS500



PIK

LPA3	page 21
LPA2 Aviation Edition	27
CML3	33
CML4	39
ICM 4.0	45
ICM 2.0	51
ICMK2.0 AZ2	57
ICS	63
ICU	69

ACMU	page 75
BS110 & BS500	83
HOW SAMPLING	92
PATCH IMAGING KIT	95
FLUID COMPATIBILITY CHARTS	99

LPA3

Portable Light Extinction Particle Analyser



Description

Contamination Monitoring Products

Portable Light Extinction Particle Analyser

MP Filtri's LPA3 is the most advanced portable particle analyser in the world. Whether you are working in the lab or in the field, the LPA3 delivers a fast, accurate and comprehensive hydraulic health check in a robust yet portable package.

Its real-time monitoring and predictive maintenance technology safeguards machinery, enhances performance and productivity, and reduces costs and unplanned downtime.

Featuring the latest breakthroughs in optical and photodiode technology, the LPA3 enhances the reliability and longevity of complex hydraulic systems and is ideal for quality control in in-house manufacturing applications. The LPA3 is compatible with the full range of Bottle Samplers.

Features & Benefits

- Online/realtime monitoring
- Comprehensive hydraulic health check
- Proactive maintenance capabilities
- High-speed sample times
- Programmable 10.1" (25.6 cm) touchscreen display
- Perfectly portable at just 10 kg
- Programmable sample volumes
- Precision Instrument
- Live trend analysis option
- Measures and displays the following international standard formats; ISO 4406, NAS 1638, AS 4059E&G, GBT 14039, GJB420B, GOST 17216, ISO 11218
- Moisture and temperature sensing
- Data logging and enhanced 4000 test result memory
- Key performance information at a glance
- CMP View Software (included)
- Ideal for hydraulic, lubrication, and subsea fluids
- Integrated printer
- Full accessories kit included
- Long-life Lithium Ion battery



Front facing view



Right facing view



Closed case
Front facing view



Closed case
Side view

Technical data

Technology

High precision LED light extinction
automatic optical particle analyser

Particle Sizing

>4, 6, 14, 21, 25, 38, 50, 70 $\mu\text{m}_{(c)}$

Analysis range

ISO 4406 Codes 8 to 24
NAS 1638 Class 2 to 12
AS4059/ISO 11218 Rev E, Table 1 Size Codes 2-12
AS4059/ISO 11218 Rev E, Table 2 Size Codes, A: 000 TO 12, B: 00 to 12,
C: 00 to 12, D: 2 to 12, E: 4-12, F: 7 to 12
AS4059 Rev G, Table 1 Size Codes 2-12
AS4059 Rev G, Table 2 Size Codes cpc
[000 to 12, 00 to 12, 00 to 12, 2 to 12, 4 to 12, 7 to 12]
GBT14039 Codes 8-24
GJB420B Size Codes, A: 000 to 12, B: 00 to 12, C: 00 to 12,
D: 2 to 12, E: 4-12, F: 7 to 12
GOST 17216
ISO11218
Please Note: Lower Limits are Test Volume dependent

Accuracy

$\pm 1/2$ ISO code for 4, 6, 14 $\mu\text{m}_{(c)}$
 ± 1 code for 21, 25, 38, 50, 70 $\mu\text{m}_{(c)}$

Calibration

Individually calibrated with ISO Medium Test Dust (MTD)
based on ISO 11171, on equipment certified by I.F.T.S to ISO 11943

Viscosity range

Up to 400 cSt

Fluid temperature

From +5 °C to +80 °C (from +41 °F to +176 °F)

Ambient temperature

From -10 °C to +80 °C (from -14 °F to +176 °F)

Pressure

Minimum: 2.0 bar / 29 psi
Maximum: 420 bar / 6092 psi static

Sample Volume

Maximum 100 ml / 3.38 fl. oz. per pump stroke.

Test time

Test volumes programmable by end user.
Pre-set volumes also available.

Moisture Sensing

% RH (Relative Humidity) $\pm 3\%$

Temperature Measurement

± 3 °C

Data Storage

Approximately 4000 timestamped tests in the integral LPA3 memory

System Pressure Measurement

$\pm 0.5\%$ Full Scale Accuracy Min 10 bar (145 psi)

Communication options

2 USB output ports
1 x USB B type for direct connection to PC and software
1 x USB A type for direct data download to USB memory stick

Environmental Protection

IP66 (lid closed)
IP54 (lid open)

Weight

10 kg (22 lb)

Dimensions

Width: 470 mm (18 1/2")
Height (not inc handle): 350 mm (13 25/32")
Depth: 170 mm (6 11/16")

Supply Voltage

18 - 19 Vdc

Power

Long-life Lithium Ion internal rechargeable battery (mains charger)

Outer Casing Finish

Copolymer Polypropylene

Wetted parts

M - C46400 Cu alloy, 316 stainless steel, PTFE, FR4, Sapphire, FPM
N - 316 stainless steel, FPM, Sapphire, FPM
S - 316 stainless steel, PTFE, FFKM, sapphire, FR4

Battery Life

Up to 8 hours

Software

CMP View software (included)

LPA3 is supplied with a full software package and digital product information

Scope of Supply

- 1 x LPA3 (*)
- 1 x M16x2 microbore pressure hose, 1500 mm long, pouch
- 1 x 2000 mm quick-release waste hose for LPA3 and pouch
- 1 x 1L waste receptacle
- 1 x 19V power adapter; 1 x UK (Type G); 1 x US (Type B); 1 x EU (Type F); 1 x CN/AUS (Type I)
- 1 x USB cable
- 1 x Digital USB copy of user guides/software/drivers
- 2 x Hard copy of calibration certificate
- 5 x Thermal printer paper
- 1 x Carry bag

(*) Specific model will be as per ordered item

FEATURES PRODUCT TECHNOLOGY

Exclusive MP Filtri technology

Featuring the latest breakthroughs in LED and photodiode technology, the LPA3 delivers increased accuracy combined with excellent repeatability.

W-Option

Water Saturation level (RH%) and fluid temperature sensor option.

P-Option

Live Pressure Readout (bar/psi) on display screen.

LED light source

A single point high accuracy LED measures particles across all sizes giving increased accuracy with excellent repeatability.

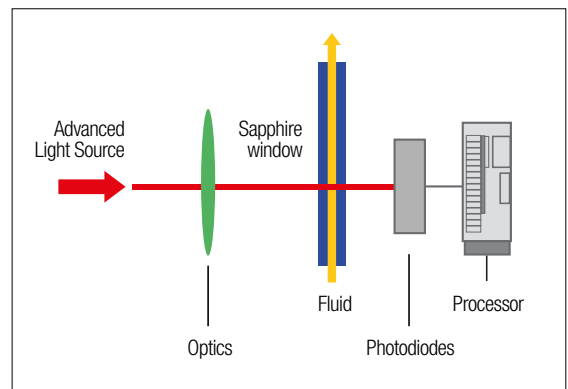
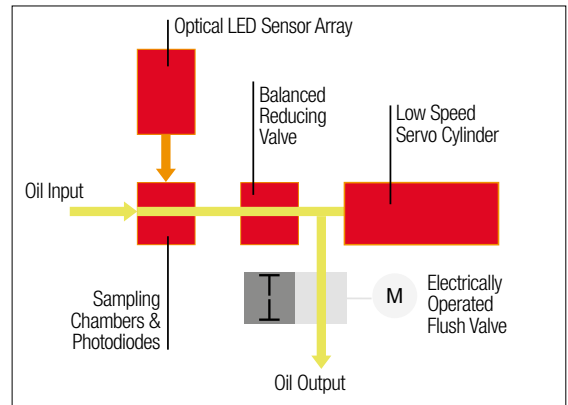

CMP View Software

Our new CMP View software is used with all MP Filtri CMP devices. When connected to CMP View, MP Filtri CMP devices can transfer results in realtime, or alternatively, historical results can be downloaded from each device's in-built memory.

- Windows compatible
- Included free with CMP Products
- Brand new design, created in-house for ease of use
- Comprehensive functionality
- Can be mastered quickly without the need for formal training
- Key results and data available at-a-glance
- Full adjustment and control of product settings, test times and alarms
- Easy test report generation
- Full trend analysis
- Universal format across our contamination monitoring product range
- Multi-machine monitoring



Dimensions

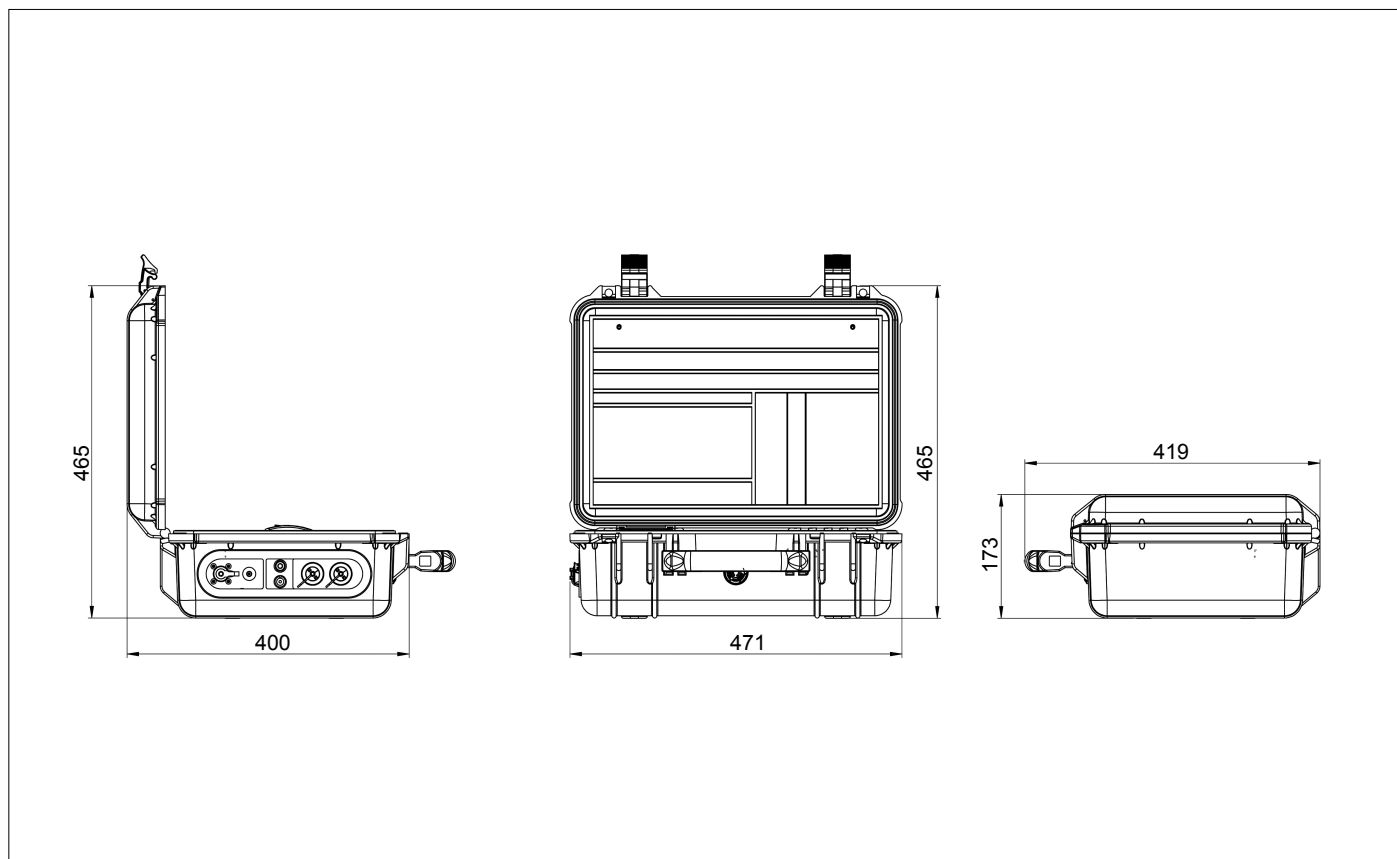

Designation & Ordering code

CONTAMINATION MONITORING - LPA3		Configuration example: LPA3					
Series	LPA3	W	P	M	1	0	1
LPA3	Portable Light Extinction Particle Analyser						
Moisture Sensor							
O	Without moisture and temperature sensor						
W	With moisture and temperature sensor						
Pressure Sensor							
O	Without on-screen inlet pressure display						
P	With on-screen inlet pressure display						
Fluid compatibility							
M	Mineral oil and synthetic fluid						
N	M type fluids & Subsea fluids and water based fluids (*)						
S	M & N type fluids & phosphate esters and aggressive fluids						
External Result							
1	With on board printer						
Design Reference							
0	Std option with full accessory kit and carry bag						
Country Plug Type							
1	1 x 19V power adapter; 1 x UK (Type G); 1 x US (Type B); 1 x EU (Type F); 1 x CN/AUS (Type I)						

(*) N version, moisture sensor (W) not available

Available with Screen Protector (Part number 63.095000). Consult your local branch for further details

LPA2 Aviation Edition

Portable Twin-laser Particle Analyser



**Airbus sampling
valve adaptor
and C spanner**

Description

Contamination Monitoring Products

Portable twin-laser Particle Analyser

The Airbus-approved LPA2 Aviation Edition is a highly precise, lightweight & fully portable instrument that has been created exclusively for the Aviation industry. It can automatically measure and display particulate contamination, moisture and temperature levels in various hydraulic fluids. The LPA2 can be connected to the MP range of bottle sampler products to enable laboratory based particle counting.

The LPA2 is a solution for online monitoring of contamination in your hydraulic fluid, providing an immediate hydraulic health check. It employs predictive maintenance procedures to help reduce downtime and in turn costs.

Features & Benefits

- Airbus-approved
- Online/real-time monitoring
- Immediate hydraulic health check
- Predictive maintenance
- Reduced downtime for MRO teams
- Lower service and maintenance costs
- The lightest machine in its class
- Fully portable
- Precision Instrument
- Full Calibration based on ISO 11171
- Measures and displays the following international standard formats; ISO 4406, NAS 1638, AS 4059E&G, GBT 14039, GJB420B, ISO 11218, GOST 17216
- Moisture and temperature sensing
- Data logging and 600 test result memory
- Manual and remote control flexibility
- Full size QWERTY keyboard
- Various test programme settings
- Full accessories kit included
- Internal rechargeable battery capable of performing 100 tests between charges



Front facing view

Right facing view

Closed case
Right facing view

Closed case
Left facing view

Airbus sampling
valve adapter and
C spanner

Technical data

Technology

Twin laser and twin optical diode detectors based light extinction automatic optical particle analyser

Particle Sizing

>4,6,14,21,25,38,50,70 $\mu\text{m}_{(c)}$ to ISO 4406 Standard

Analysis range

ISO 4406 Codes 8 to 24
 NAS 1638 Class 2 to 12
 AS4059/ISO 11218 Rev E, Table 1 Size Codes 2-12
 AS4059/ISO 11218 Rev E, Table 2 Size Codes, A: 000 TO 12, B: 00 to 12,
 C: 00 to 12, D: 2 to 12, E: 4-12, F: 7 to 12
 AS4059 Rev G, Table 1 Size Codes 2-12
 AS4059 Rev G, Table 2 Size Codes cpc
 [000 to 12, 00 to 12, 00 to 12, 2 to 12, 4 to 12, 7 to 12]
 GBT14039 Codes 8-24
 GJB420B Size Codes, A: 000 to 12, B: 00 to 12, C: 00 to 12,
 D: 2 to 12, E: 4-12, F: 7 to 12
 ISO 11218
 GOST 17216
 Please Note: Lower Limits are Test Volume dependent

Accuracy

Better than 3% typical

Calibration

Each unit individually calibrated with ISO Medium Test Dust (MTD) based on ISO 11171, on equipment certified by I.F.T.S. to ISO 11943

Viscosity range

Up to 400 cSt

Fluid temperature

From +5 °C to +80 °C (from +41 °F to +176 °F)

Ambient Temperature

From -10 °C to +80 °C (from -14 °F to +176 °F)

Pressure Max

Minimum 2.0 bar / 29 psi (gauge) required
 Maximum: 400 bar / 5800 psi (gauge)

Sample Volume / Test time

8 ml. (short): 2:50- Recommended for set up only
 15 ml. (normal): 5:00
 30 ml. (dynamic): 10:00
 24 ml. (bottle sampler): 8:00
 15 ml. (continuous): 5:00

Moisture Sensing

% RH (Relative Humidity) $\pm 3\%$

Temperature Measurement

$\pm 3\%$

Data Storage

Up to 600 tests

Communication options

RS232 9 pin D plug

System Pressure Measurement

$\pm 0.5\%$ Full Scale Accuracy Min 10 bar (145 psi)

Environmental Protection

IP51 (lid open)

Weight

LPA2: 9.8 kg (21.6 lb)
 LPA2 Aviation Edition with travel case - packed: 18.5 kg (40.8 lb)

Dimensions

LPA2:
 Width 436 mm (17 11/64")
 Height 218 mm (8 37/64")
 Depth 268 mm (10 1/2")

LPA2 Aviation Edition with travel case - packed:

Width 400 mm (15 3/4")
 Height 500 mm (19 11/16")
 Length 600 mm (23 5/8")

Supply Voltage

9 - 36 Vdc

Power

Internal rechargeable battery (mains charger)

Outer Casing Finish

Anodised Aluminium

Wetted parts

S - 316 stainless steel, PTFE, FFKM, sapphire, FR4

Battery Life

Up to 100 tests

Software

CMP View software (included)

LPA2 is supplied with a full software package and digital product information**Scope of Supply**

- 1 x LPA2 (Model: LPA20PSTA030)
- 1 x Airbus sampling valve adapter* and C spanner
- 1 x M16x2 microbore pressure hose, 2500 mm long
(For the Airbus Sampling Adaptor)
- 1 x EN6123-04 to M16x2 microbore pressure hose
2500mm long (compatible with A350 sampling valve)
- 1 x 1L waste receptacle
- 1 x 12V, 2A power adapter c/w UK/EU/US/AUS/CN heads
- 1 x 9 pin serial cable
- 1 x USB to serial converter
- 1 x 3 pin socket for external signals
- 1 x Hard copy of product user guide
- 1 x Digital copy of user guides/software/drivers
- 2 x Hard copy of calibration certificate
- 2 x Thermal printer paper
- 1 x Carry bag
- 1 x Digital copy of the Airbus Operator's Guide

(*) Specific model will be as per ordered item

FEATURES PRODUCT TECHNOLOGY

Exclusive MP Filtri technology

The combination of the two lasers with a unique optics and photodiode package enables the LPA2 to give increased accuracy combined with excellent repeatability.

P-Option

Live Pressure Readout (bar) on display screen.

Laser 1

A single point high accuracy laser measures particles of contamination at $4 \mu\text{m}_{(c)}$ and $6 \mu\text{m}_{(c)}$ giving increased accuracy with excellent repeatability.

Laser 2

Standard accuracy laser specifically designed for system contaminants between $6 \mu\text{m}_{(c)}$ and $70 \mu\text{m}_{(c)}$.

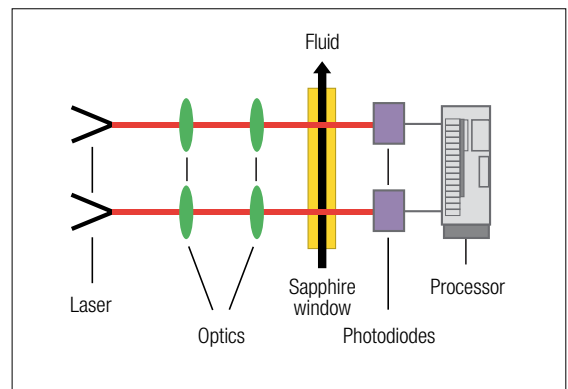
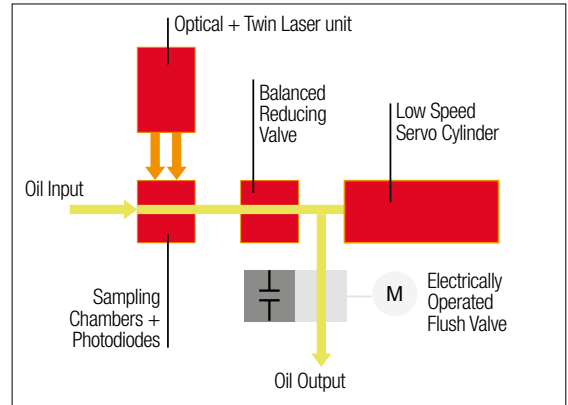

CMP View Software

Our new CMP View software is used with all MP Filtri CMP devices. When connected to CMP View, MP Filtri CMP devices can transfer results in realtime, or alternatively, historical results can be downloaded from each device's in-built memory.

- Windows compatible
- Included free with CMP Products
- Brand new design, created in-house for ease of use
- Comprehensive functionality
- Can be mastered quickly without the need for formal training
- Key results and data available at-a-glance
- Full adjustment and control of product settings, test times and alarms
- Easy test report generation
- Full trend analysis
- Universal format across our contamination monitoring product range
- Multi-machine monitoring



Dimensions

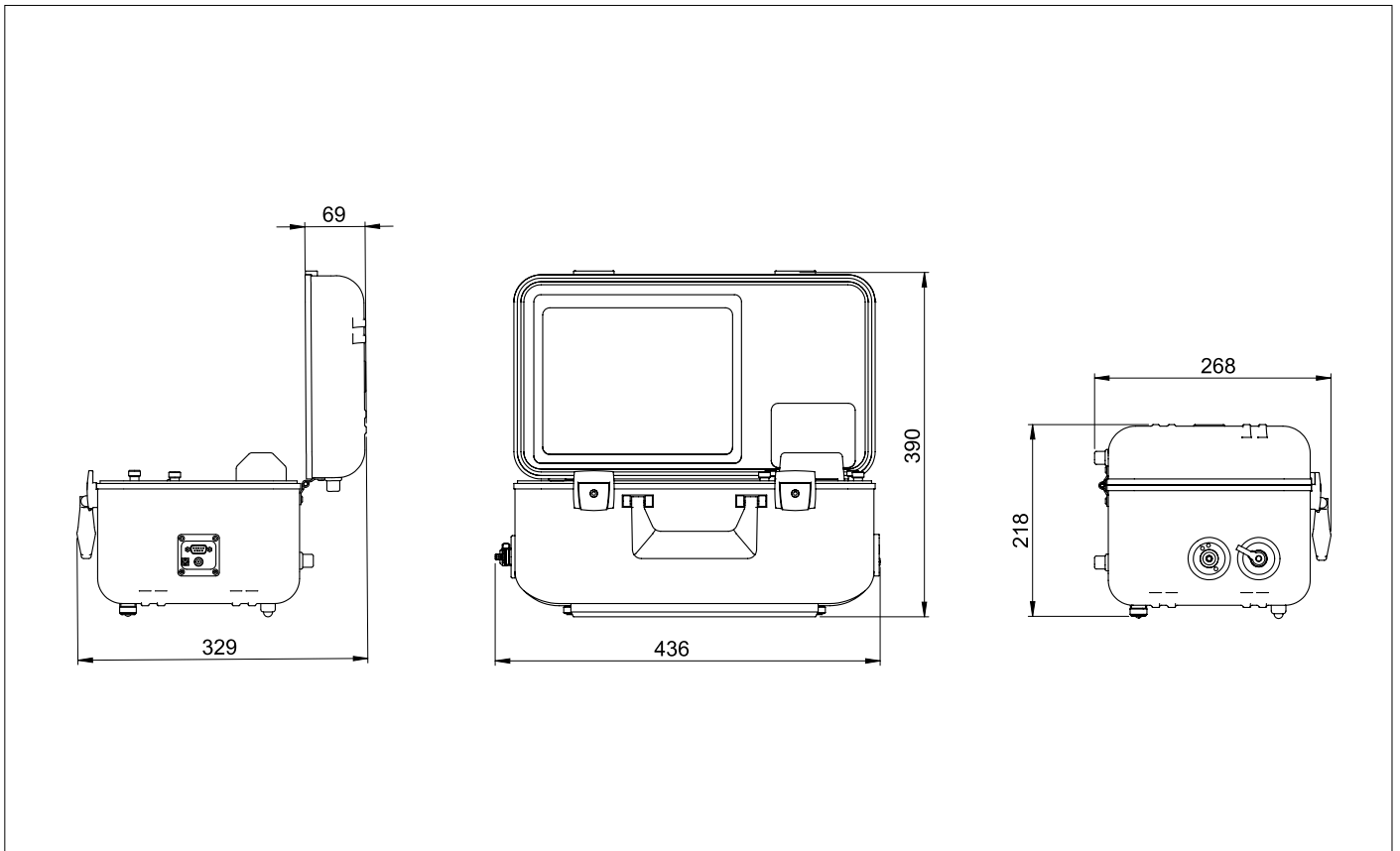

Designation & Ordering code

CONTAMINATION MONITORING - AVIATION EDITION

Series	Configuration example:	LPA2	0	P	S	T	A	30
LPA2 Portable twin-laser Particle Analyser								
Moisture Sensor								
0 Without moisture and temperature sensor								
Pressure Sensor								
P With on-screen inlet pressure display								
Fluid compatibility								
S Phosphate ester and aggressive fluids								
Accessories								
T Standard unit with travel case								
Bottle sampling options								
A With Airbus adaptor								
Design reference								
30								

CML3

Compact Portable Contamination Monitor



Description

Contamination Monitoring Products

Compact Portable Contamination Monitor

The CML3 delivers a fast, accurate assessment of contamination in the field and is the perfect solution for the mobile, construction and plant hire sectors. Easy to master, the new CML3 has been specially designed to open up the latest in contamination control technology to everyone from fleet service engineers to specialist technicians seeking an advanced hydraulic health check on critical systems. Created as a cost-effective solution, the CML3 comes with intuitive software - making real-time assessments as well as predictive maintenance and long-term trend monitoring easier than ever before

Features & Benefits

- High-resolution 7" (178 mm) touchscreen display
- Real-time contaminant results at-a-glance
- Proactive maintenance capabilities
- Work all-day battery
- Perfectly portable at just 7.7 kg (17 lbs)
- Easy to master - newcomers can get up and running in minutes
- Live trend analysis option
- Measures and displays the following international standard formats: ISO 4406; NAS 1638; AS4059 Rev E, Table 1; AS4059 Rev E, Table 2; AS4059 Rev G, Table 1; AS4059 Rev G, Table 2; GBT 14039; GJB 420 B; GOST 17216, ISO 11218
- Moisture and temperature sensing
- Data logging and enhanced 4000 test result memory
- Key performance information at a glance
- CMP View software (included)
- Full accessories kit included
- High Pressure Sampling Up to 420 bar



Front facing view



Right facing view



Closed case
Left side view



Closed case
Right side view

Technical data

Technology

High precision LED light extinction
automatic optical contamination monitor

Particle Sizing

>4, >6, >14, >21, >25, >38, >50, >70 µm(c)

Analysis range

ISO 4406 Codes 8 to 24
NAS 1638 Class 2 to 12
AS4059/ISO 11218 Rev E, Table 1 Size Codes 2-12
AS4059/ISO 11218 Rev E, Table 2 Size Codes, A: 000 TO 12, B: 00 to 12,
C: 00 to 12, D: 2 to 12, E: 4-12, F: 7 to 12
AS4059 Rev G, Table 1 Size Codes 2-12
AS4059 Rev G, Table 2 Size Codes cpc
[000 to 12, 00 to 12, 00 to 12, 2 to 12, 4 to 12, 7 to 12]
GBT14039 Codes 8-24
GJB420B Size Codes, A: 000 to 12, B: 00 to 12, C: 00 to 12,
D: 2 to 12, E: 4-12, F: 7 to 12
GOST 17216
ISO 11218
Please Note: Lower Limits are Test Volume dependent

Accuracy

± 1 code

Calibration

Each unit individually calibrated with ISO Medium Test Dust (MTD)
based on ISO 11171, on equipment certified by I.F.T.S. ISO 11943

Viscosity range

Up to 400 cSt

Fluid temperature

From +5 °C to +80 °C (from +41 °F to +176 °F)

Ambient temperature

From -10 °C to +60 °C (from +14 °F to +140 °F)

Pressure

Minimum: 2.0 bar / 29 psi
Maximum: 420 bar / 6092 psi static

Moisture Sensing

% RH (Relative Humidity) ±3%

Temperature Measurement

±3%

Data Storage

Up to 4000 tests

Environmental Protection

IP65 (Lid closed)
IP54 (Lid open)

Weight

7.7 kg (17 lbs)
10 kg (22 lbs) with accessories

Dimensions

Width: 352 mm (13.8")
Height: 149 mm (5.8") (not including handle)
Depth: 297 mm (11.7")

Power

Lithium-Ion rechargeable battery

Outer Casing Finish

Copolymer Polypropylene

Wetted parts

M - C46400 Cu alloy, 316 stainless steel, PTFE, FR4, Sapphire, FPM

Battery Life

Up to 8 hours

Software

CMP View (Provided)

CML3 is supplied with a full software package and digital product information

Scope of Supply

- 1 x CML3 (*)
- 1 x M16x2 microbore pressure hose, 1500 mm (59 1/16") long, pouch
- 1 x 2000 mm (78 47/64") quick release waste hose and pouch
- 1 x 1L waste receptacle
- 1 x 19V power adapter; 1 x UK (Type G); 1 x US (Type B); 1 x EU (Type F); 1 x CN/AUS (Type I)
- 1 x USB cable
- 1 x Digital USB copy of user guides/software/drivers
- 2 x Hard copy of calibration certificate
- 1 x Carry bag

(*) Specific model will be as per ordered item

FEATURES PRODUCT TECHNOLOGY

Exclusive MP Filtri technology

Featuring the latest breakthroughs in LED and photodiode technology, the CML3 delivers outstanding accuracy combined with exceptional repeatability

W-Option

Water Saturation level (RH%) and fluid temperature sensor option.

LED light source

A single point high accuracy LED measures particles across all sizes.

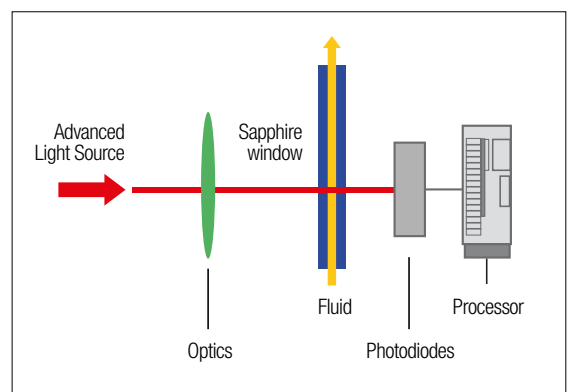
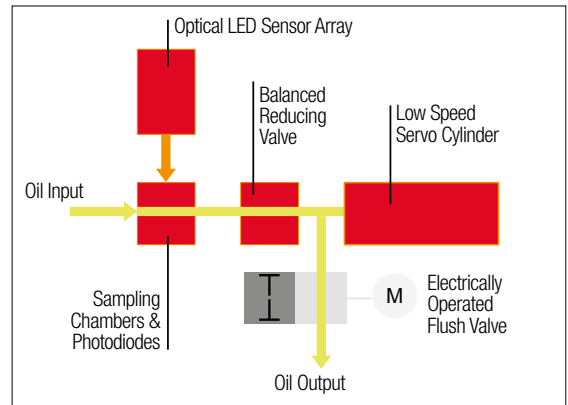

CMP View Software

Our new CMP View software is used with all MP Filtri CMP devices. When connected to CMP View, MP Filtri CMP devices can transfer results in realtime, or alternatively, historical results can be downloaded from each device's in-built memory.

- Windows compatible
- Included free with CMP Products
- Brand new design, created in-house for ease of use
- Comprehensive functionality
- Can be mastered quickly without the need for formal training
- Key results and data available at-a-glance
- Full adjustment and control of product settings, test times and alarms
- Easy test report generation
- Full trend analysis
- Universal format across our contamination monitoring product range
- Multi-machine monitoring



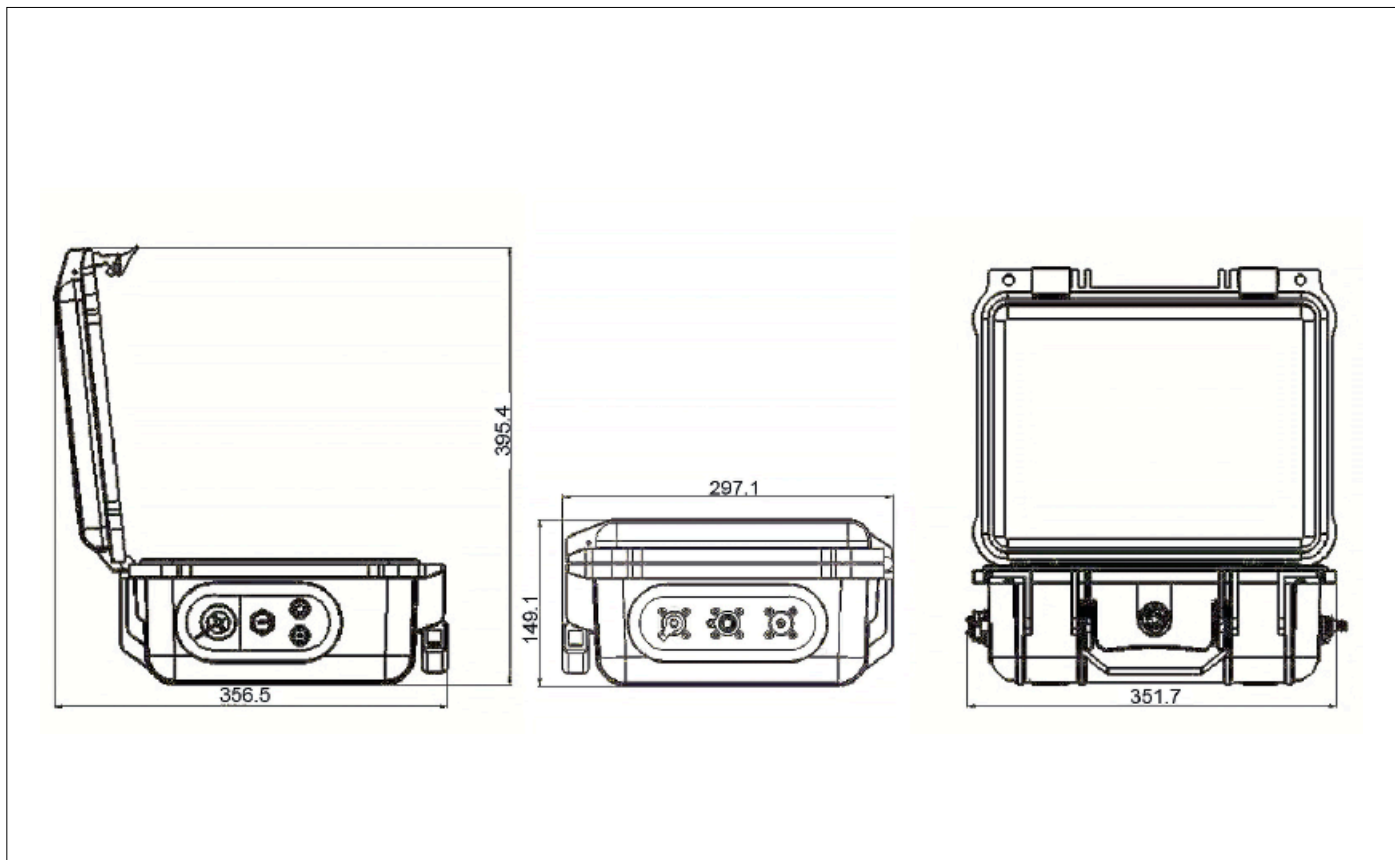

Designation & Ordering code

CONTAMINATION MONITORING - CML3

Series	Configuration example:	CML3	W	0	M	00	1
CML3 Compact portable contamination monitor							
Sensor options: Moisture							
W With moisture and temperature sensor							
0 Without							
Sensor options: Pressure							
0 Without on-screen inlet pressure display							
Fluid compatibility							
M Mineral oil and synthetic fluids							
Design Reference							
00 Standard option with full accessory kit and carry bag							
Country Plug Type							
1 UK (Type G)							
2 EU (Type F)							
3 US (Type A)							
4 AUS/CN (Type I)							

CML4

Compact Portable Contamination Monitor



Description

Contamination Monitoring Products

Compact Portable Contamination Monitor

The CML4 features a metering pump which enables analysis of both 'live' and unpressurised systems, delivering comprehensive contamination checks on any machine in any condition.

A compact and portable contamination monitor that delivers a fast, accurate assessment of contamination in the field and is the perfect solution for the mobile, construction and plant hire sectors.

Easy to master, the new CML4 features cutting-edge contamination control technology to anyone wishing to protect their critical systems.

Features & Benefits

- High-resolution 7" (178 mm) touchscreen display
- Real-time contamination results at-a-glance
- High-speed sample times
- Predictive maintenance enabled
- Unpressurised and pressurised sampling up to 420 bar
- Fully portable at just 8.5 kg
- Precision Instrument
- Easy to master - operators can get up and running in minutes
- Measures and displays the following international standard formats; ISO 4406, NAS 1638, AS 4059E&G Tables 1 and 2, ISO 11218, GBT 14039, GJB 420B, GOST 17216
- Moisture and temperature sensing
- Data logging and 4000 test result memory
- CMP View software (included on Data stick)
- Bluetooth printer (optional equipment)
- Full accessories kit included
- Work-all-day battery that can handle up to 140 tests on a single charge



Front facing view



Right facing view



Closed case
Right facing view



Closed case
Left facing view

Technical data

Technology

High precision LED light extinction
automatic optical contamination monitor

Particle Sizing

>4, >6, >14, >21, >25, >38, >50, >70 $\mu\text{m}_{(c)}$

Analysis range

ISO 4406 Codes 8 to 24
NAS 1638 Class 2 to 12
AS4059/ISO 11218 Rev E, Table 1 Size Codes 2-12
AS4059/ISO 11218 Rev E, Table 2 Size Codes, A: 000 TO 12, B: 00 to 12,
C: 00 to 12, D: 2 to 12, E: 4-12, F: 7 to 12
AS4059 Rev G, Table 1 Size Codes 2-12
AS4059 Rev G, Table 2 Size Codes cpc
[000 to 12, 00 to 12, 00 to 12, 2 to 12, 4 to 12, 7 to 12]
GBT14039 Codes 8-24
GJB420B Size Codes, A: 000 to 12, B: 00 to 12, C: 00 to 12,
D: 2 to 12, E: 4-12, F: 7 to 12
GOST 17216
ISO 11218
Please Note: Lower Limits are Test Volume dependent

Accuracy

$\pm 1/2$ ISO code for 4, 6, 14 $\mu\text{m}_{(c)}$
 ± 1 code for larger sizes

Calibration

Calibrated with ISOMTD in accordance with ISO 21018
Part 1 and Part 4

Viscosity range

Up to 400 cSt

Fluid temperature

From +5 °C to +80 °C (from +41 °F to +176 °F)

Ambient Temperature

From -10 °C to +60 °C (from -14 °F to +140 °F)

Pressure

Offline: Maximum 2.0 bar / 29 psi
Online: Maximum 420 bar / 6092 psi

Moisture Sensing

% RH (Relative Humidity) $\pm 3\%$

Temperature Measurement

± 3 °C

Data Storage

Up to 4000 tests

Environmental Protection

IP65 (lid closed)
IP54 (lid open)

Weight

8.5 kg (18.7 lb) (unit only)

Dimensions

Width: 352 mm (13.8")
Height: 149 mm (5.8") (not including handle)
Depth: 297 mm (11.7")

Power

Lithium-Ion rechargeable battery

Outer Casing Finish

Copolymer Polypropylene

Wetted parts

M - C46400 Cu alloy, 316 stainless steel, PTFE, FR4, Sapphire, FPM

Battery Life

Up to 8 hours

Software

CMP View (Provided)

**CML4 is supplied with a full software package
and digital product information**

Scope of Supply

- 1 x CML4 (Model: CML4WOM00*)
- 1 x M16 x 2 Microbore pressure hose, 1500 mm (59 1/16") long + pouch
- 1 x 2000 mm (78 47/64") quick release waste hose + pouch
- 1 x 1L Waste container
- 1 x 19V power adapter; 1 x UK (Type G); 1 x US (Type B); 1 x EU (Type F); 1 x CN/AUS (Type I)
- 1 x USB Stick with digital copies of product user guides, CMP View software, accessory products, drivers and product brochures
- 2 x Hard copy certificate of calibration
- 1 x 1500 mm quick-release offline hose and pouch (Low pressure)
- 1 x USB C to USB A cable

* see designation and ordering code

FEATURES PRODUCT TECHNOLOGY

Exclusive MP Filtri technology

Featuring the latest breakthroughs in LED and photodiode technology, the CML4 delivers outstanding accuracy combined with exceptional repeatability

W-Option

Water Saturation level (RH%) and fluid temperature sensor option.

LED light source

A single point high accuracy LED measures particles across all sizes.

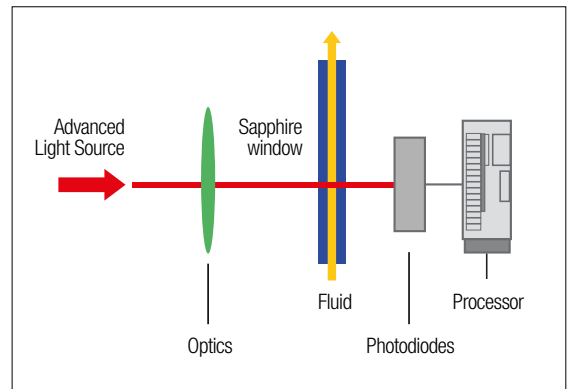
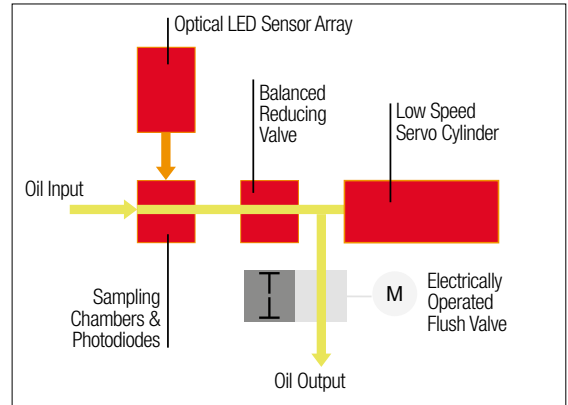

CMP View Software

Our new CMP View software is used with all MP Filtri CMP devices. When connected to CMP View, MP Filtri CMP devices can transfer results in realtime, or alternatively, historical results can be downloaded from each device's in-built memory.

- Windows compatible
- Included free with CMP Products
- Brand new design, created in-house for ease of use
- Comprehensive functionality
- Can be mastered quickly without the need for formal training
- Key results and data available at-a-glance
- Full adjustment and control of product settings, test times and alarms
- Easy test report generation
- Full trend analysis
- Universal format across our contamination monitoring product range
- Multi-machine monitoring



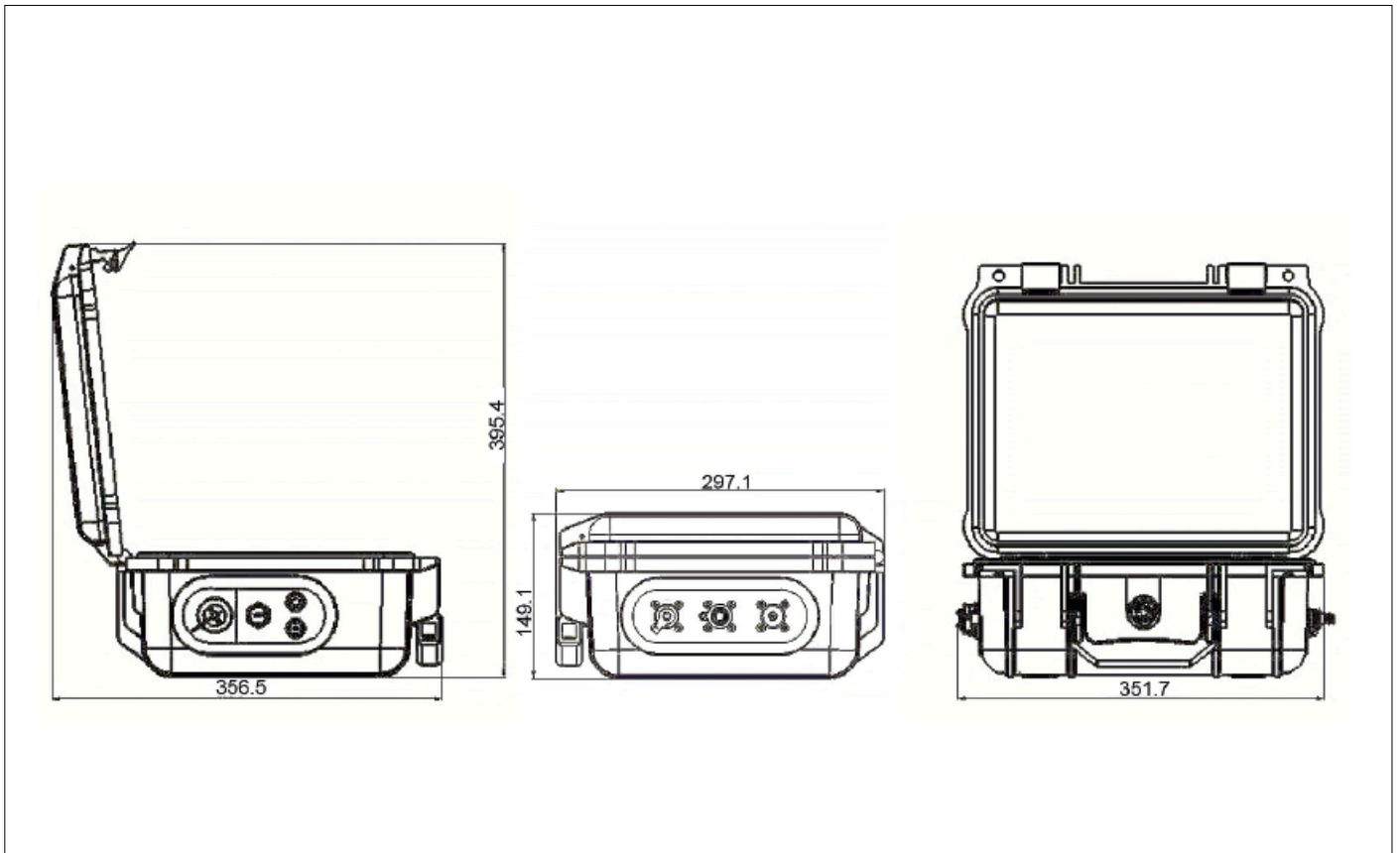

Designation & Ordering code

CONTAMINATION MONITORING - CML4

Series	Configuration example:	CML4	W	0	M	00	1
CML4 Light extinction compact portable contamination monitor							
Moisture Sensor							
W With moisture and temperature sensor							
Design Reference							
0 Standard option							
Fluid compatibility							
M Mineral oil and synthetic fluids							
Design Reference							
00 Standard option with full accessory kit and carry bag							
Country Plug Type							
1 UK (Type G)							
2 US (Type F)							
3 EU (Type A)							
4 CN/AUS (Type I)							

ICM 4.0

WiFi-enabled In-line Contamination Monitor



Description

Contamination Monitoring Products

Wifi-enabled In-line Contamination Monitor

The ICM 4.0 automatically measures and displays particulate contamination, moisture and temperature levels in various hydraulic fluids. Designed to deliver the power of connectivity to operators and be fully Industry 4.0 compliant, the ICM 4.0 features a reliable in-built wifi hub. It is designed specifically to be mounted directly to systems, where ongoing measurement or analysis is required, and where space and costs are limited.

Features & Benefits

- Integrated WiFi
- WiFi connectivity with CMP View
- 8 channel contamination measurement & display
- Measures and displays the following international standard formats; ISO 4406, NAS 1638, AS 4059E&G, GBT 14039, GJB420B, GOST 17216, ISO 11218
- Moisture and temperature sensing fluid dependent
- Data logging and 4000 test result memory
- Manual, automatic and remote control flexibility
- Multicolour indicators via LCD (K versions) and LED with output alarm signals as standard
- Robust die cast aluminium construction
- CMP View Software (included)
- Pressure max. 420 bar
- Environmental protection IP65/67 versatile
- Secondary connector to allow the simultaneous control/download of results during operation
- RS485, Modbus, CANbus and 4-20mA analogue output as standard

Status LED

All ICM 4.0 versions have a multicolour indicator on the front panel, which is used to indicate the status or alarm state. ICM-K versions also have a screen that changes colour. The alarm thresholds can be set from CMP View.

Screen and multicolor indicators

- Green indicates that the test result passed, i.e. none of the alarm thresholds were exceeded
- Yellow indicates that the lower cleanliness limit was exceeded, but not the upper one
- Red indicates that the upper cleanliness limit was exceeded
- Blue indicates that the upper water content limit was exceeded
- Red/Blue Alternating indicates both cleanliness and water content upper limits exceeded
- Violet indicates that the upper temperature limit was exceeded



Technical data

Technology

LED based light extinction
automatic optical particle analyser

Particle Sizing

>4, 6, 14, 21, 25, 38, 50, 70 $\mu\text{m}_{(c)}$

Analysis range

ISO 4406 Codes 8 to 24
NAS 1638 Class 2 to 12
AS4059/ISO 11218 Rev E, Table 1 Size Codes 2-12
AS4059/ISO 11218 Rev E, Table 2 Size Codes, A: 000 TO 12, B: 00 to 12,
C: 00 to 12, D: 2 to 12, E: 4-12, F: 7 to 12
AS4059 Rev G, Table 1 Size Codes 2-12
AS4059 Rev G, Table 2 Size Codes cpc
[000 to 12, 00 to 12, 00 to 12, 2 to 12, 4 to 12, 7 to 12]
GBT14039 Codes 8-24
GJB420B Size Codes, A: 000 to 12, B: 00 to 12, C: 00 to 12,
D: 2 to 12, E: 4-12, F: 7 to 12
GOST 17216
ISO 11218
Please Note: Lower Limits are Test Volume dependent

Accuracy

$\pm 1/2$ ISO code for 4, 6, 14 $\mu\text{m}_{(c)}$
 ± 1 code for 21, 25, 38, 50, 70 $\mu\text{m}_{(c)}$

Calibration

Individually calibrated with ISO Medium Test Dust (MTD)
based on ISO 11171, on equipment certified by I.F.T.S. ISO 11943

Operating Flow Rate

20 - 400 ml/min (0.005 - 0.1 gpm/min)

Viscosity range

Up to 1000 cSt

Fluid temperature

From -25 °C to +80 °C (from -13 °F to +176 °F)

Ambient Temperature

From -10 °C to +55 °C (from -14 °F to +131 °F)

Pressure

Minimum: 0.5 bar / 7.25 psi
Maximum: 420 bar/ 6092 psi static

Test time

Adjustable 10 - 3600 seconds. Factory set to 120 seconds.
Start delay & programmable test intervals available as standard

Flow rate measurement

Indicator only

Moisture Sensing

% RH (Relative Humidity) $\pm 3\%$

Temperature Measurement

± 3 °C

Data Storage

Up to 4000 tests

Communication options

RS485, MODBUS, CANBUS, 4-20mA time multiplex as standard

Relays

Two solid state relays fitted to "R" version for output to alarm circuits

Environmental Protection

IP 65/67 versatile IK04 Impact Protection

Weight

1.6 kg (3.5 lb)

Dimensions

Width 142 mm (5 19/32")
Height 123 mm (4 27/32")
Depth 65 mm (2 9/16")

Supply Voltage

9 - 36 Vdc

Power consumption

<2.2 W

Outer Casing Finish

Polyurethane BS X34B. Colour BS381-638 (Dark Sea Grey)
Industry 4.0 ready with appropriate accessory product

Wetted parts

M - C46400 Cu alloy, 316 stainless steel, PTFE, FR4, Sapphire, FPM
N - 316 stainless steel, FPM, Sapphire, FPM
S - 316 stainless steel, PTFE, FFKM, sapphire, FR4

Software

CMP View Software (included)

ICM 4.0 is supplied with a full software package and digital product information

Scope of Supply

- 1 x ICM 4.0 (Specific model will be as per ordered item)
- 1 x 3m Twisted Pair Cable Assembly
- 1 x Hard copy Quick start/wiring installation guide
- 1 x Hard copy Fluid Condition Handbook
- 1 x Digital copy of user guides/software/drivers
- 2 x Hard copy of calibration certificate

Wifi Connectivity

Wifi connectivity ensures you can access and share real-time data and analysis instantly via a number of different platforms.

- All connections from ICM 4.0:
Modbus, Canbus, 4-20mA signal and Switched alarm relay outputs (WiFi replaces the need for the remote connector).
Non-WiFi Connections also available.
- Cloud based systems:
Capability to connect to customers own cloud-based systems via Modbus.
User access to all ICMs on the same network, including remotely via VPN.
- Web browser readouts:
Generated from the unique IP address of each ICM 4.0.

CMP View Software

Our new CMP View software is used with all MP Filtri CMP devices. When connected to CMP View, MP Filtri CMP devices can transfer results in realtime, or alternatively, historical results can be downloaded from each device's in-built memory.

- Windows compatible
- Included free with CMP Products
- Brand new design, created in-house for ease of use
- Comprehensive functionality
- Can be mastered quickly without the need for formal training
- Key results and data available at-a-glance
- Full adjustment and control of product settings, test times and alarms
- Easy test report generation
- Full trend analysis
- Universal format across our contamination monitoring product range
- Multi-machine monitoring



Hydraulic Circuit

TYPICAL PRESSURE LINE

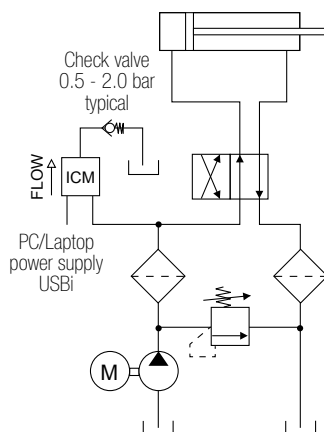

TYPICAL RETURN LINE

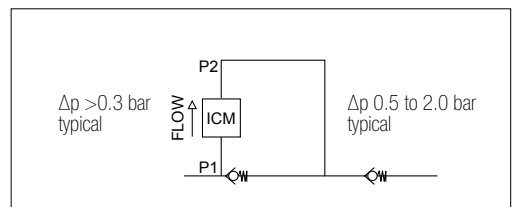
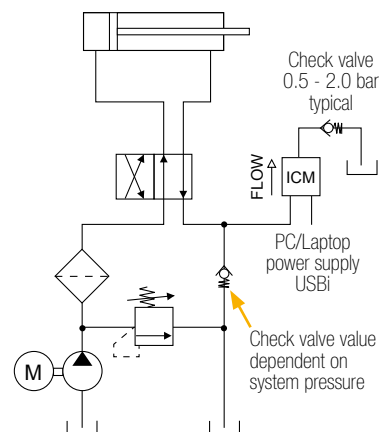

Dimensions

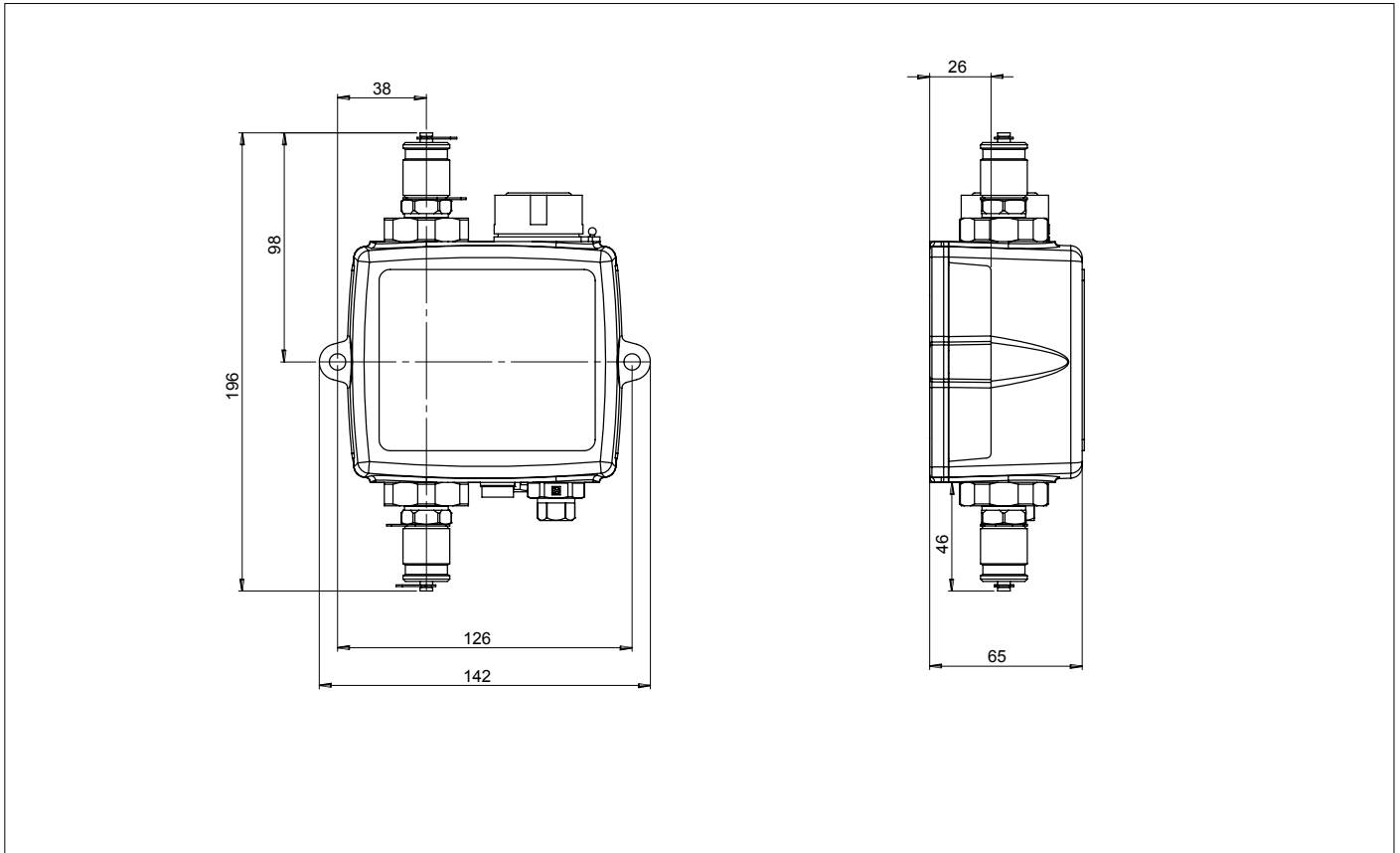

Designation & Ordering code

CONTAMINATION MONITORING - ICM 4.0

Series	Configuration example:	ICM	W	M	K	R	G1	4.0
ICM In-line Contamination Monitor								
Moisture Sensor (RH%)								
0 Without moisture and temperature sensor								
W With moisture and temperature sensor								
Fluid compatibility								
M Mineral/synthetic oils								
N Subsea and water based fluids (*)								
S M & N type fluids & phosphate esters/aviation fluids - G3 port option only								
Keypad / Display								
0 Without LCD and keypad control								
K With LCD and keypad control								
Device output								
R With relays / external alarm outputs								
Connections								
G1 M16x2 test points								
G3 1/4"BSPP female ports								
G4 7/16th UNF female ports								
Series								
4.0 ICM 4.0 with integral WiFi								

(*) N version, moisture sensor (W) not available

ICM 2.0

In-Line Contamination Monitor



ICM 2.0 GENERAL INFORMATION

Description

Contamination Monitoring Products

In-Line Contamination Monitor

The ICM 2.0 automatically measures and displays particulate contamination, moisture and temperature levels in various hydraulic fluids. It is designed specifically to be mounted directly to systems, where ongoing measurement or analysis is required, and where space and costs are limited.

Features & Benefits

- 8 channel contamination measurement & display
- Measures and displays the following international standard formats; ISO 4406, NAS 1638, AS 4059E&G, GBT 14039, GJB420B, GOST 17216, ISO 11218
- Moisture and temperature sensing fluid dependent
- Data logging and 4000 test result memory
- Manual, automatic and remote control flexibility
- Multicolour indicators via LCD (K versions) and LED with output alarm signals as standard
- Robust die cast aluminium construction
- CMP View Software (included)
- Pressure max. 420 bar
- Environmental protection IP65/67 versatile
- Secondary connector to allow the simultaneous control/download of results during operation
- Option available to download all results onto a USB stick, direct from the ICM
- RS485, Modbus, CANbus and 4-20mA analogue output as standard

Status LED

All ICM 2.0 versions have a multicolour indicator on the front panel, which is used to indicate the status or alarm state. ICM-K versions also have a screen that changes colour. The alarm thresholds can be set from CMP View.

Screen and multicolor indicators

- Green indicates that the test result passed, i.e. none of the alarm thresholds were exceeded
- Yellow indicates that the lower cleanliness limit was exceeded, but not the upper one
- Red indicates that the upper cleanliness limit was exceeded
- Blue indicates that the upper water content limit was exceeded
- Red/Blue Alternating indicates both cleanliness and water content upper limits exceeded
- Violet indicates that the upper temperature limit was exceeded



Technical data

Technology

LED based light extinction
automatic optical contamination monitor

Particle Sizing

>4, 6, 14, 21, 25, 38, 50, 70 $\mu\text{m}_{(c)}$

Analysis range

ISO 4406 Codes 8 to 24
NAS 1638 Class 2 to 12
AS4059/ISO 11218 Rev E, Table 1 Size Codes 2-12
AS4059/ISO 11218 Rev E, Table 2 Size Codes, A: 000 TO 12, B: 00 to 12,
C: 00 to 12, D: 2 to 12, E: 4-12, F: 7 to 12
AS4059 Rev G, Table 1 Size Codes 2-12
AS4059 Rev G, Table 2 Size Codes cpc
[000 to 12, 00 to 12, 00 to 12, 2 to 12, 4 to 12, 7 to 12]
GBT14039 Codes 8-24
GJB420B Size Codes, A: 000 to 12, B: 00 to 12, C: 00 to 12,
D: 2 to 12, E: 4-12, F: 7 to 12
GOST 17216
ISO 11218

Please Note: Lower Limits are Test Volume dependent

Accuracy

$\pm 1/2$ ISO code for 4, 6, 14 $\mu\text{m}_{(c)}$
 ± 1 code for 21, 25, 38, 50, 70 $\mu\text{m}_{(c)}$

Calibration

Individually calibrated with ISO Medium Test Dust (MTD) based on ISO 11171, on equipment certified by I.F.T.S. ISO 11943

Operating Flow Rate

20 - 400 ml/min (0.005 - 0.1 gpm/min)

Viscosity range

Up to 1000 cSt

Fluid temperature

From -25 °C to +80 °C (from -13 °F to +176 °F)

Ambient Temperature

Non K version: from -25 °C to +80 °C (from -13 °F to +176 °F)
K version: from -25 °C to +55 °C (from -13 °F to +131 °F)

Pressure

Maximum: 420 bar / 6092 psi

Test time

Adjustable 10 - 3600 seconds. Factory set to 120 seconds.
Start delay & programmable test intervals available as standard

Flow rate measurement

Indicator only

Moisture Sensing

% RH (Relative Humidity) $\pm 3\%$

Temperature Measurement

± 3 °C

Data Storage

Up to 4000 tests

Communication options

RS485, MODBUS, CANBUS, 4-20mA time multiplex as standard

Relays

Two solid state relays fitted to "R" version for output to alarm circuits

Environmental Protection

IP 65/67 versatile IK04 Impact Protection

Weight

1.6 kg (3.5 lb)

Dimensions

Width 142 mm (5 19/32")
Height 123 mm (4 27/32")
Depth 65 mm (2 9/16")

Supply Voltage

9 - 36 Vdc

Power consumption

<2.2 W

Outer Casing Finish

Polyurethane BS X34B. Colour BS381-638 (Dark Sea Grey)
Industry 4.0 ready with appropriate accessory product

Wetted parts

M - C46400 Cu alloy, 316 stainless steel, PTFE, FR4, Sapphire, FPM
N - 316 stainless steel, FPM, Sapphire, FPM
S - 316 stainless steel, PTFE, FFKM, sapphire, FR4

Software

CMP View software (included)

ICM 2.0 is supplied with a full software package and digital product information

Scope of Supply

- 1 x ICM 2.0 (Specific model will be as per ordered item)
- 1 x 3m Twisted Pair Cable Assembly
- 1 x Hard copy Quick start/wiring installation guide
- 1 x Hard copy Fluid Condition Handbook
- 1 x Digital copy of user guides/software/drivers
- 2 x Hard copy of calibration certificate

CMP View Software

Our new CMP View software is used with all MP Filtri CMP devices. When connected to CMP View, MP Filtri CMP devices can transfer results in realtime, or alternatively, historical results can be downloaded from each device's in-built memory.

- Windows compatible
- Included free with CMP Products
- Brand new design, created in-house for ease of use
- Comprehensive functionality
- Can be mastered quickly without the need for formal training
- Key results and data available at-a-glance
- Full adjustment and control of product settings, test times and alarms
- Easy test report generation
- Full trend analysis
- Universal format across our contamination monitoring product range
- Multi-machine monitoring



Hydraulic Circuit

TYPICAL PRESSURE LINE

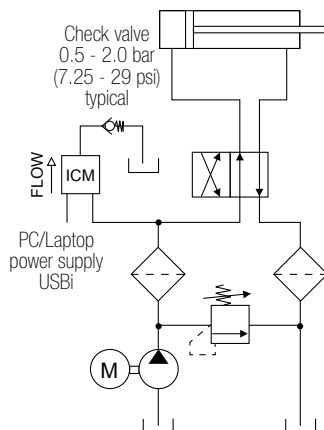

TYPICAL RETURN LINE

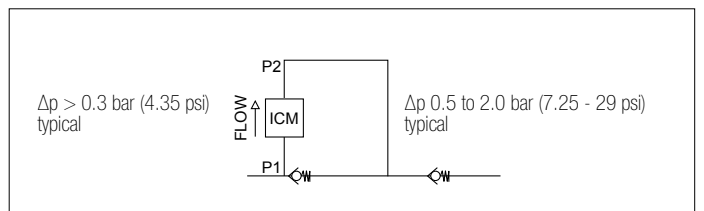
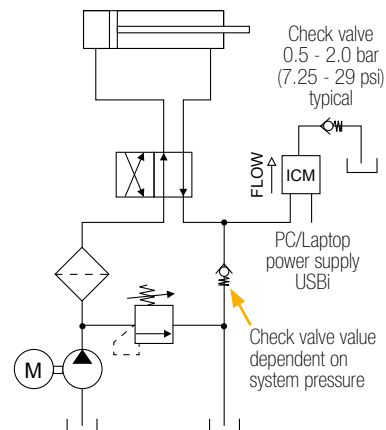

Dimensions

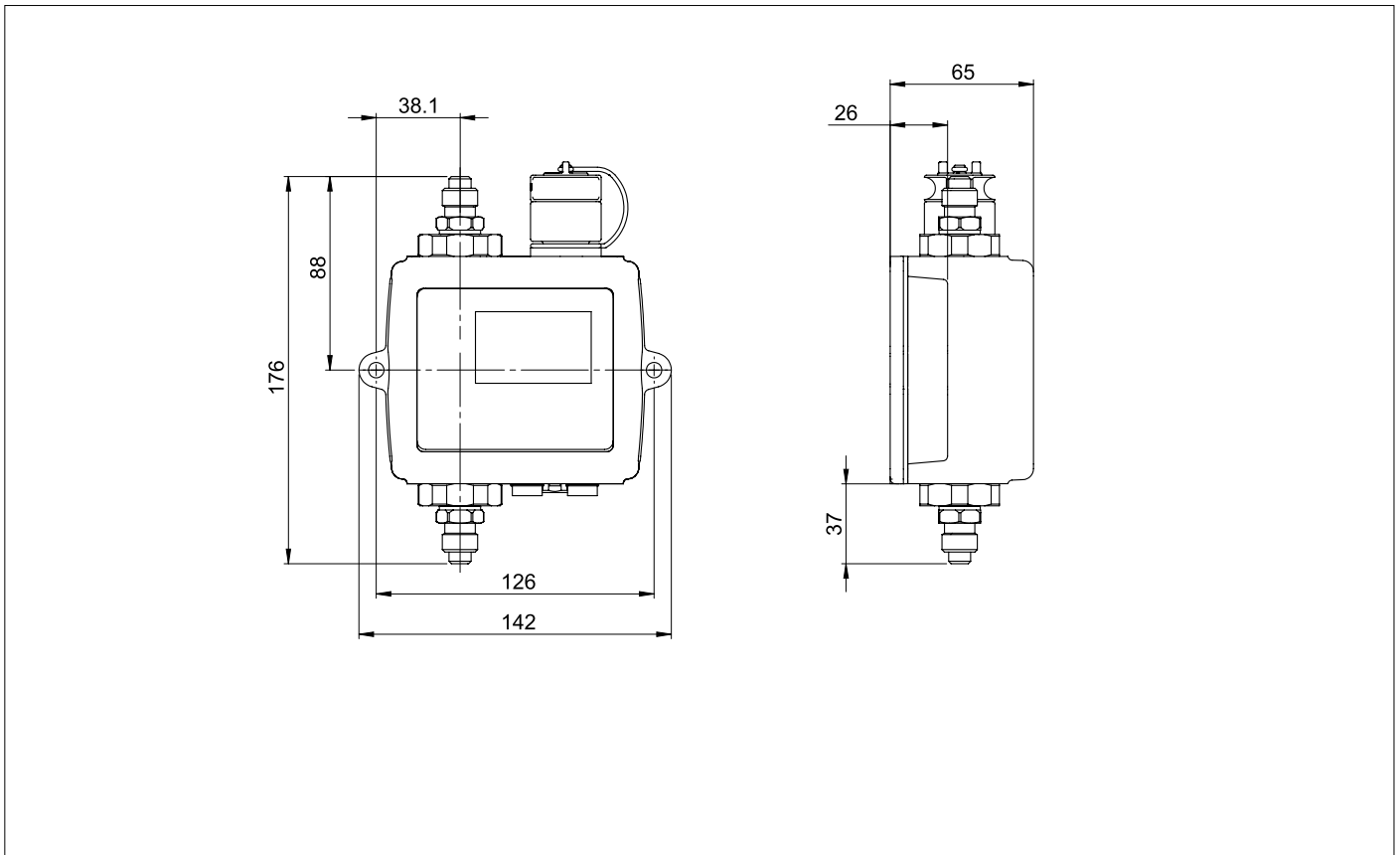

Designation & Ordering code

CONTAMINATION MONITORING ICM 2.0	
Series	Configuration example: ICM W M K R G1 2.0
ICM In-Line Contamination Monitor	
Moisture Sensor (RH%)	
0 Without moisture and temperature sensor	
W With moisture and temperature sensor	
Fluid compatibility	
M Mineral/synthetic oils	
N Subsea fluids and water based fluids (*)	
S Phosphate ester and aggressive fluids	
Keypad / Display	
0 Without keypad / display	
K With keypad / display	
Device output	
R With relays / external alarm outputs	
U Test record transfer (direct to USB stick) plus relays/external alarm outputs	
Connections	
G1 ICM complete with M16x2 pressure test point connections fitted	
G3 1/4" BSP - Female port	
G4 7/16" UNF - Female port	
Series	
2.0	

(*) N version, moisture sensor (W) not available

ICMK2.0 AZ2

ATEX Inline Contamination Monitor 



Description

Contamination Monitoring Products

ATEX Inline Contamination Monitor

Our ICMK2.0 AZ2 contamination monitor can automatically measure and save particulate contamination, moisture and temperature levels in various hydraulic fluids. It is designed specifically to be mounted directly to systems, where ongoing measurement or analysis is required, in high risk or explosive environments.

Features & Benefits

- ATEX zone II Cat. 3G
- Calibrated to relevant ISO standard
- Manual, automatic and remote control flexibility
- Various communication protocols as standard inc. RS485, Modbus, CANbus, and 4-20mA
- Award-winning CMP View software
- 8-channel contamination measurement and display
- Measures and displays the following international standard formats; ISO 4406, ISO 11218, NAS 1638, SAE AS 4059 revision E and G tables 1 & 2, GBT 14039, GJB 420 B, GOST 17216
- Moisture and temperature sensing (fluid dependent)
- Data logging and 4000 test result memory
- Multicolour indicators via LCD screen with output alarm signals as standard
- Robust die cast stainless steel construction (Max pressure 420 bar)
- Environmental protection IP66

Status LED

All ICMK2.0 AZ2 versions have a multicolour indicator on the front panel, which is used to indicate the status or alarm state. ICM-K versions also have a screen that changes colour. The alarm thresholds can be set from CMP View.

Multicolor indicators

- Green indicates that the test result passed, i.e. none of the alarm thresholds were exceeded
- Yellow indicates that the lower cleanliness limit was exceeded, but not the upper one
- Red indicates that the upper cleanliness limit was exceeded
- Blue indicates that the upper water content limit was exceeded
- ● Red/Blue Alternating indicates both cleanliness and water content upper limits exceeded
- Violet indicates that the upper temperature limit was exceeded



Front facing view



Left facing view



Top facing view



Bottom facing view

Technical data

Technology

LED based light extinction
automatic optical contamination monitor

Particle Sizing

>4, 6, 14, 21, 25, 38, 50, 70 $\mu\text{m}_{(c)}$

Analysis range

ISO 4406 Codes 8 to 24
NAS 1638 Class 2 to 12
AS4059/ISO 11218 Rev E, Table 1 Size Codes 2-12
AS4059/ISO 11218 Rev E, Table 2 Size Codes, A: 000 TO 12,
B: 00 to 12,
C: 00 to 12, D: 2 to 12, E: 4-12, F: 7 to 12
AS4059 Rev G, Table 1 Size Codes 2-12
AS4059 Rev G, Table 2 Size Codes cpc
[000 to 12, 00 to 12, 00 to 12, 2 to 12, 4 to 12, 7 to 12]
GBT14039 Codes 8-24
GJB420B Size Codes, A: 000 to 12, B: 00 to 12, C: 00 to 12,
D: 2 to 12, E: 4-12, F: 7 to 12
GOST 17216
ISO 11218
Please Note: Lower Limits are Test Volume dependent

Accuracy

$\pm 1/2$ ISO code for 4, 6, 14 $\mu\text{m}_{(c)}$
 ± 1 code for 21, 25, 38, 50, 70 $\mu\text{m}_{(c)}$

Calibration

Each unit individually calibrated with ISO Medium Test Dust (MTD)
based on ISO 11171, on equivalent certified by I.F.T.S. ISO 11943

Operating Flow Rate

20 - 400 ml/min (0.005 - 0.1 gpm/min)

Viscosity range

≤ 1000 cSt

Fluid temperature

From -25 °C to +55 °C (from -13 °F to +176 °F)

Ambient Temperature

From -25 °C to +55 °C (from -13 °F to +176 °F)

Pressure

Maximum: 420 bar / 6092 psi static

Flow rate measurement

Indicator only

Moisture sensing and temperature measurement

% saturation (RH) and fluid temperature (°C)

Data Storage

4000 tests

Test time

Adjustable: 10-3600 times. Factory set to 120 seconds
Start delay and programmable test intervals available as standard

Communication options

RS485, 4-20mA, MODBUS, CANbus as standard

Relays

Two solid state relays fitted to "R" version for output to alarm circuits

Environmental Protection

IP66 (lid closed)
IP54 (lid open)

Weight

10 kg (22 lb)

Dimensions

Width 186 mm (7 21/64")
Height 320 mm (12 19/32")
Depth 130 mm (5 1/8")

Supply Voltage

9 - 36 Vdc

Current Supply

12V - 150mA
24V - 80mA
36V - 60mA

Power consumption

<2.2 W

Outer Casing Finish

Stainless Steel

Wetted parts

M - C46400 Cu alloy, 316 stainless steel, PTFE, FR4, Sapphire, FPM
N - 316 stainless steel, FPM, Sapphire, FPM
S - 316 stainless steel, PTFE, FFKM, sapphire, FR4

Software

CMP View Software (included)

Atex classification

CE ⚡ II 3 G Ex nR IIB T5 GC IP66

ICMK2.0 AZ2 cable wiring details

MP Filtri do not supply an ATEX approved cable with the ICMK2.0 AZ2 products as customers may run such cables through varying ATEX zones. Wiring diagrams supplied, please consult product user guide for full information.

Note: an adapter cable and ICMUSBi product will be required should CMP View be utilised as the control software. These accessories are only suitable for use outside of the zoned areas

ICMK2.0 AZ2 is supplied with a full software package and digital product information**Scope of Supply**

- 1 x ICMK2.0 AZ2 (*)
- 1 x ATEX approved non wired cable connector and gland
- 1 x Hard copy Fluid Condition Handbook
- 1 x Digital copy of user guides/software/drivers
- 2 x Hard copy of calibration certificate
- 1 x Hard copy of ATEX certificate(*)

(*) Specific model will be as per ordered item

CMP View Software

Our new CMP View software is used with all MP Filtri CMP devices. When connected to CMP View, MP Filtri CMP devices can transfer results in realtime, or alternatively, historical results can be downloaded from each device's in-built memory.

- Windows compatible
- Included free with CMP Products
- Brand new design, created in-house for ease of use
- Comprehensive functionality
- Can be mastered quickly without the need for formal training
- Key results and data available at-a-glance
- Full adjustment and control of product settings, test times and alarms
- Easy test report generation
- Full trend analysis
- Universal format across our contamination monitoring product range
- Multi-machine monitoring



Hydraulic Circuit

TYPICAL PRESSURE LINE

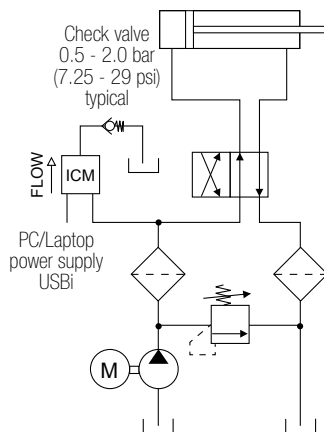

TYPICAL RETURN LINE

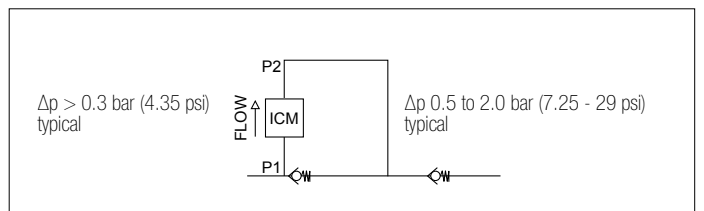
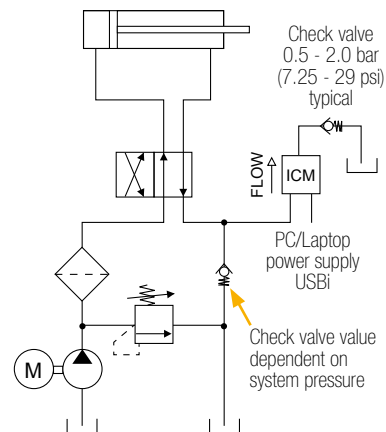

Dimensions

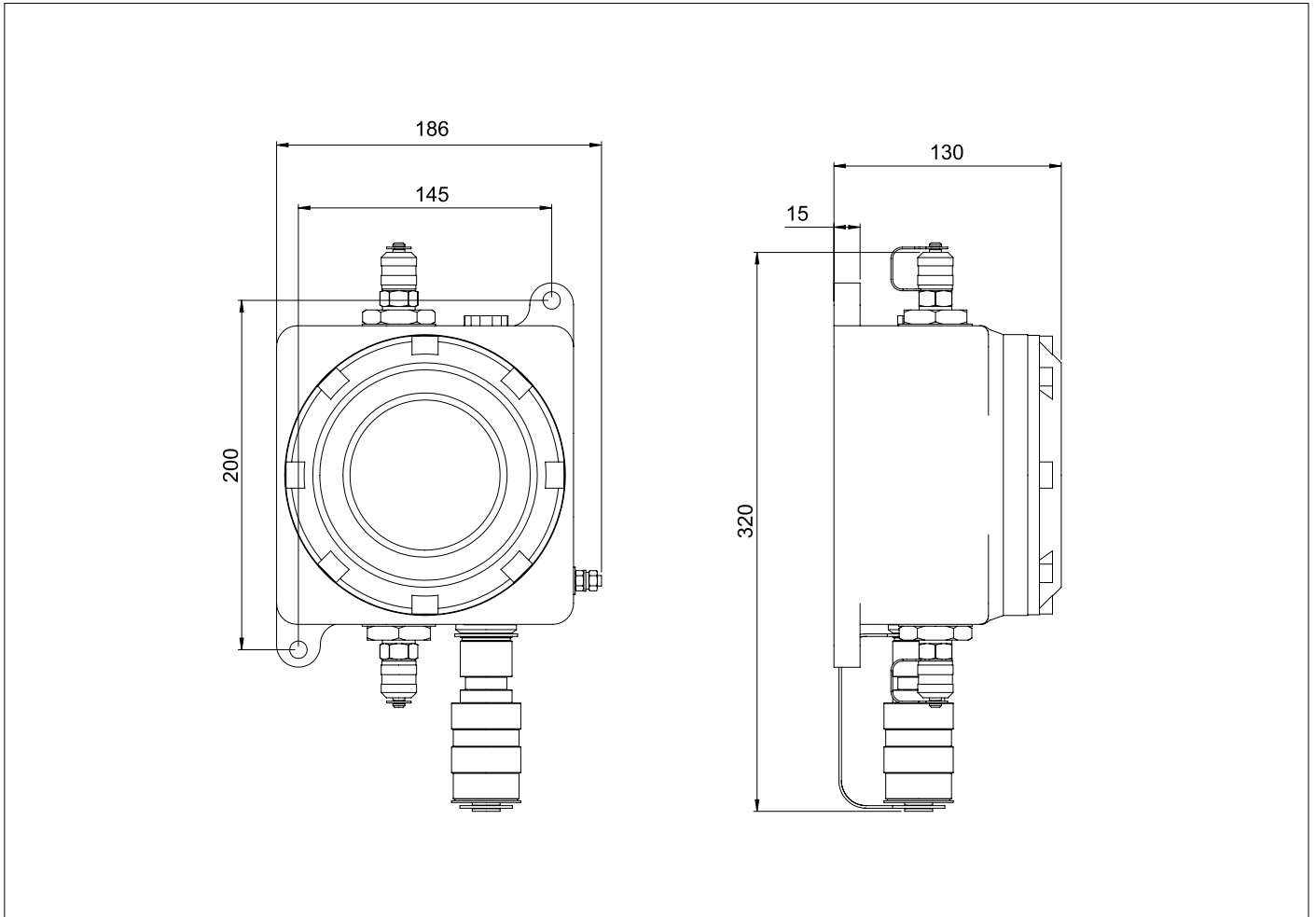

Designation & Ordering code

INLINE CONTAMINATION MONITOR ICMK2.0 AZ2

Series	Example:	ICM	W	M	K	R	G1	2.0AZ2
ICM Light extinction contamination monitor								
Moisture Sensor (RH%)								
O Without moisture and temperature sensor								
W With moisture and temperature sensor (*)								
Fluid compatibility								
M Mineral/synthetic oils								
N Subsea fluids and water based fluids								
S Phosphate ester and aggressive fluids								
Display								
K With on-screen display								
Alarm relays								
R With alarm relays								
Connections								
G1 1/4" M16x2 test point								
Series								
2.0AZ2 Version 2.0 ATEX								

(*) not available in **N** version

ICS

Inline Contamination Sensor



Description

Contamination Monitoring Products

In-line Contamination Sensor

The ICS automatically measures particulate contamination levels in various hydraulic fluids and is designed for industrial and mobile applications.

It is designed to be inline mounted directly to systems, where ongoing measurement or analysis is required and where space and costs are limited

Features & Benefits

- Inline mounting
- 3-channel contamination measurement
- Measures ISO 4406
- Space-efficient design
- Robust build quality
- Pressure max. 420 bar (6091 psi)
- Environmental Protection:
 - Mobile version: IP69K
 - Industrial version: IP67
- Impact Protection:
 - Mobile version: IK04
 - Industrial version: IK04
- 4-20mA analogue output (Industrial)
- RS485 Modbus RTU (Industrial)
- CANbus (Mobile)



Technical data

Technology

LED based light extinction
automatic optical contamination sensor

Particle Sizing

>4, 6, 14 µm(c)

Analysis range

ISO 4406 Codes 0 to 24 (test time dependent)

Accuracy

± 1/2 code for 4,6,14 µm (c) across the analysis range

Calibration

Each unit individually calibrated with ISO Medium Test Dust (MTD)
based on ISO 11171, on equipment certified by I.F.T.S. ISO 11943

Operating Flow Rate

20 to 400 ml/minute

Viscosity range

≤ 1000 cSt

Fluid temperature

Industrial version:
From -25 °C to +80 °C (from -13 °F to +176 °F)
Mobile version:
From -25 °C to +100 °C (from -13 °F to +212 °F)

Ambient Temperature

Industrial version:
From -25 °C to +80 °C (from -13 °F to +176 °F)
Mobile version:
From -25 °C to +80 °C (from -13 °F to +176 °F)

Pressure

Minimum: 0.5 bar / 7.25 psi
Maximum: 420 bar / 6091 psi

Communication options

Industrial Version: 4-20mA time multiplexed; RS485 Modbus RTU
Mobile Version: CANbus

Environmental Protection

Industrial version: IP67; Impact Protection IK04
Mobile version: IP69K; Impact Protection IK04

Weight

0.9 kg (2 lbs)

Dimensions

Industrial version:
Width 58 mm (2 9/32")
Height 68 mm (2 43/64")
Depth 50 mm (2")

Mobile version:
Width 58 mm (2 9/32")
Height 76 mm (3")
Depth 50 mm (2")

Electrical Supply

Industrial version: 24v DC +/- 20%
Mobile version: 9-36v DC

Power consumption

<1.5 W

Outer Casing Finish

Stainless steel 316

Wetted parts

M - C46400 Cu alloy, 316 stainless steel, PTFE, FR4, Sapphire, FPM

Fluid compatibility

Mineral oils, synthetic fluids

Electrical load (Mobile version only)

In accordance with ISO 16750-2

Mechanical load (Mobile version only)

In accordance with ISO 16750-3

Cable

Industrial version only: Electrical cable has to be ordered separately
(optional accessory), MP Filtri item no. 13.061000 - ICU/ICS Cable M12
4-pin 1.5m long.

Scope of Supply

- 1 x ICS*
- 2 x Hard copy of calibration certificate
- 1 x Datasheet with installation guide and user manual
- 1 x Hard-copy quick start guide
- 1 x digital copy of user guides /software / drivers

* Version as specified

Dimensions

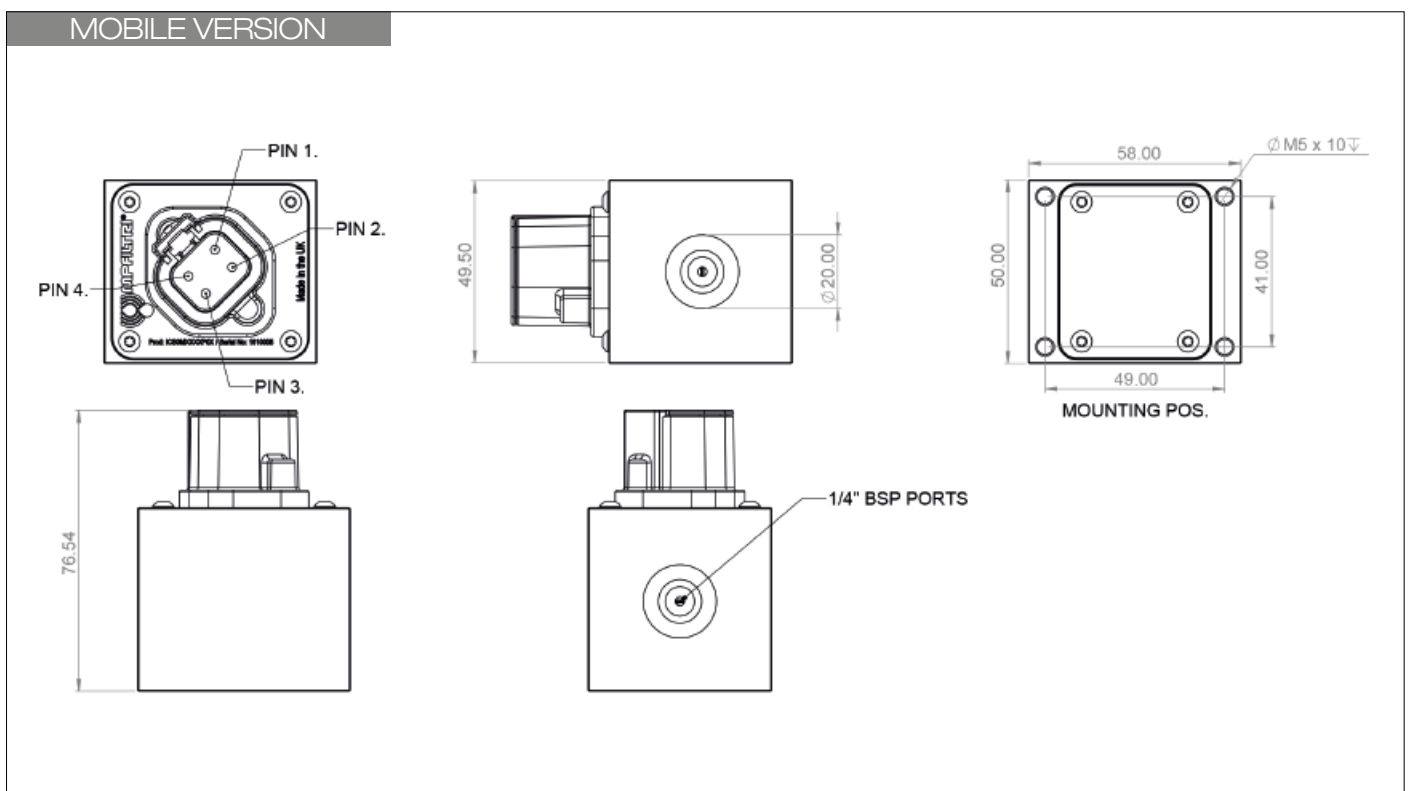
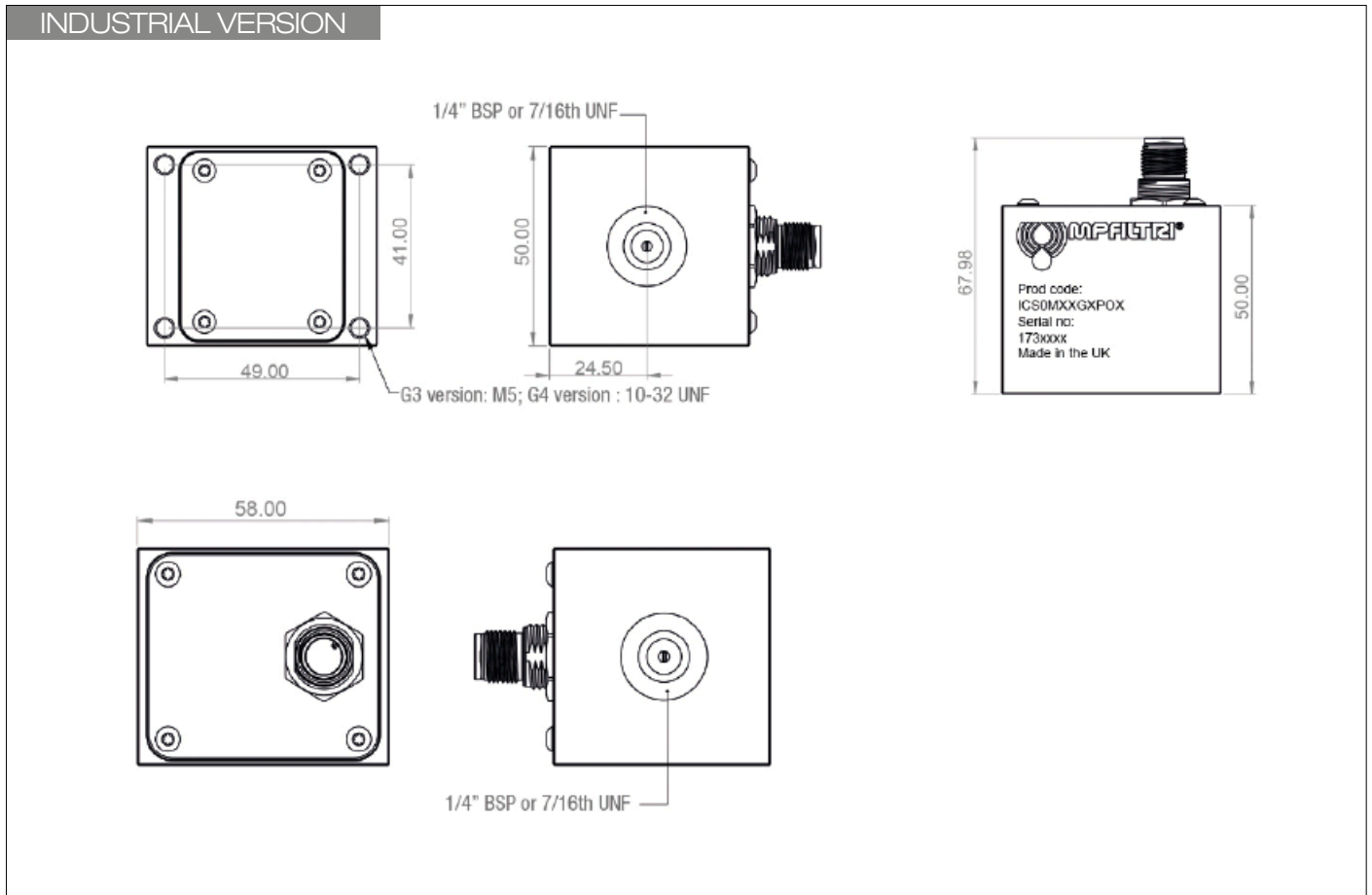

Designation & Ordering code

ICS INLINE CONTAMINATION MONITORING SENSOR		Configuration example: ICS 0 M 0 0 G3 P01						
Contamination Monitoring Product	ICS Inline Contamination Monitoring Sensor							
Sensor options	0 Standard							
Fluid compatibility	M Mineral oil and synthetic fluids							
Communication protocol	0 420mA 1 RS485 Modbus RTU 2* CANBUS							
Electric connection	0 M12 4pin 1* DTP10-4P							
Port Options	G3 1/4" BSPP Female G4 7/16th UNF Female							
Design Ref	P01 Standard							

* Mobile version only

ICU

In-line Contamination Monitoring Unit



Description

Contamination Monitoring Products

In-line Contamination Monitoring Unit

The ICU automatically measures particulate contamination levels in various hydraulic fluids and is designed for industrial applications. It is designed to be manifold mounted directly to systems, where ongoing measurement or analysis is required, and where space and costs are limited.

Features & Benefits

- Manifold mounting
- 3 channel contamination measurement
- Measures ISO 4406
- Robust design and construction
- Pressure max. 350 bar
- Environmental protection IP65/67 versatile
- 4-20mA analogue output as standard



Right facing view



Front / Left facing view

Technical data

Technology

LED based light extinction
automatic optical contamination monitor

Particle Sizing

>4, 6, 14 $\mu\text{m}_{(c)}$

Analysis range

ISO 4406 Code 0 to 20

Accuracy

$\pm 1/2$ ISO code for 4, 6, 14 $\mu\text{m}_{(c)}$

Calibration

Individually calibrated with ISO Medium Test Dust (MTD) based on ISO 11171, on equipment certified by I.F.T.S. ISO 11943

Operating Flow Rate

200 ml/minute controlled by the built in flow control valve

Viscosity range

Up to 1000 cSt

Fluid temperature

From +25°C to +80 °C (from 32 °F to +176 °F)

Ambient Temperature

From -25 °C to +80 °C (from -13 °F to +176 °F)

Pressure

Minimum: 0.5 bar / 7 psi
Maximum: 350 bar / 5075 psi

Test time

Adjustable 180 seconds as standard

Communication options

4-20 mA time multiplex as standard

Environmental Protection

IP67 IK04

Weight

1.4 kg (3 lb)

Dimensions

Width 93 mm (3 21/32")
Height 50 mm (2")
Depth 80 mm (3")

Supply Voltage

24 Vdc $\pm 20\%$

Power consumption

<2.2 W

Outer Casing Finish

C46400 Copper Alloy

Wetted parts

M - C46400 Cu alloy, 316 stainless steel, PTFE, FR4, Sapphire, FPM

Cable

Electrical cable has to be ordered separately (optional accessory),
MP Filtri item no. 13.061000 - ICU Cable M12 4 pin 1.5m long

ICU is supplied with a full software package and digital product information**Scope of Supply**

- 1 x ICU0M00G5P04
- 1 x Installation kit:
 - 4 x M6x1.0x55 mm long fixing bolts
 - 2 x 6.50 ID x 1.5 CSD FKM o-ring seals
- 2x Hard copy of calibration certificate
- 1 x digital copy of user guides /software / drivers

Dimensions

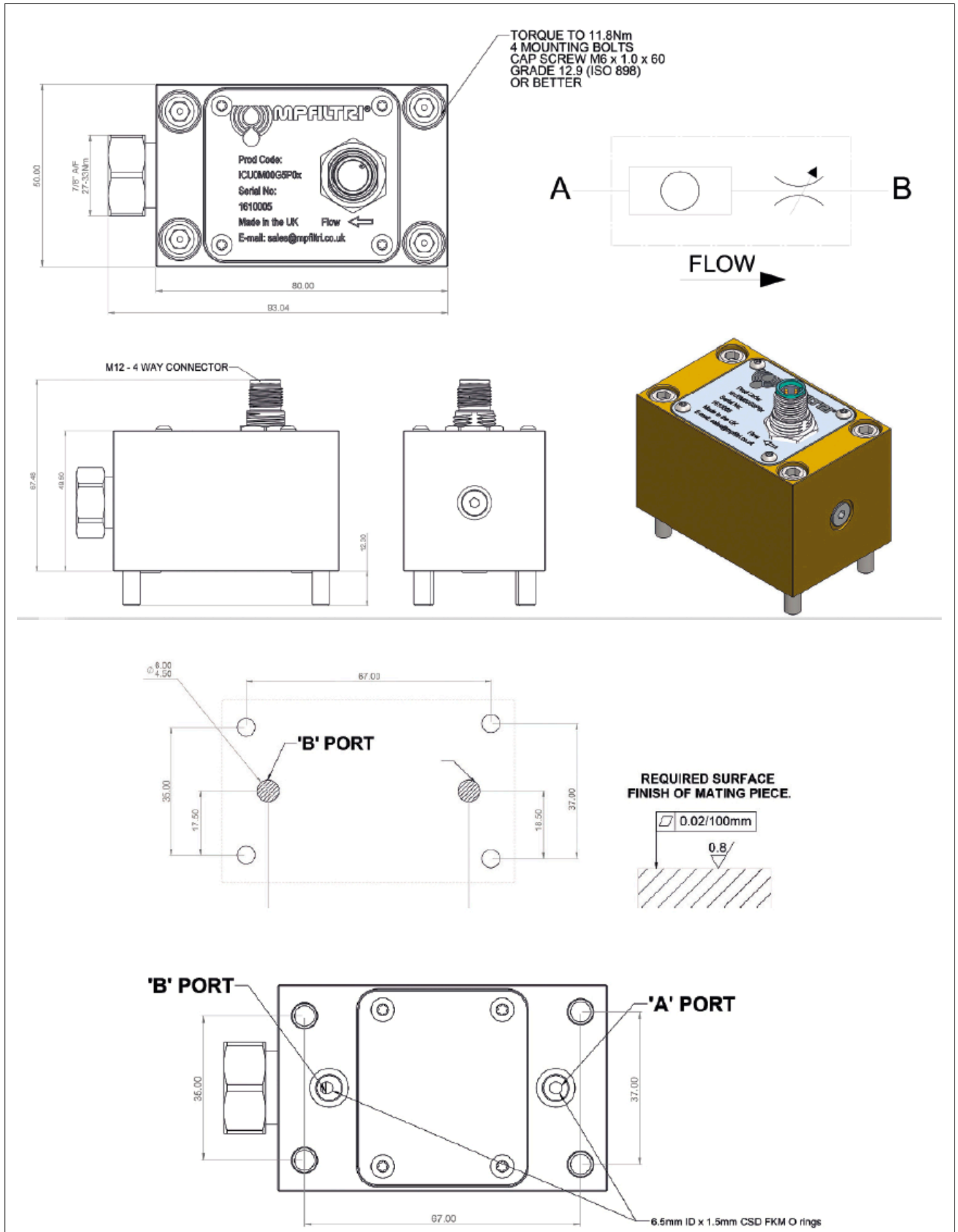

Designation & Ordering code

ICU IN-LINE CONTAMINATION MONITORING UNIT	
Contamination Monitoring Product ICU Inline Contamination Monitoring Unit	Configuration example: ICU 0 M 0 0 G5 P04
Sensor options 0 Standard	
Fluid compatibility M Mineral oil and synthetic fluids	
Communication protocol 0 4-20mA	
Electric connection 0 M12 4pin	
Port Options G5 Bespoke port design	
Design Ref P04 ICU Mk2 version	

ACMU

Auxiliary Contamination Monitoring Unit



Description

Contamination Monitoring Products

Auxiliary Contamination Monitoring Unit

MP Filtri UK's ACMU combines technology to enable sampling on low pressure hydraulic and lubrication systems where aeration can be an issue. The ACMU suppresses the air bubbles so they are no longer counted as particles.

The ACMU can be installed in most low pressure hydraulic and lubrication systems.

Utilising the best contamination monitor product in its class as standard, the ACMU delivers the simplicity, practicality and accuracy for the most demanding of applications.

Features & Benefits

Where can it be used?

- Wind/Tidal/Wave Energy
- Gearbox applications
- Gearbox monitoring
- Offshore & ship systems
- Lubrication & Oil systems
- Mobile Equipment
- Test Benches

When should it be used?

- Entrained air or turbulent flows
- Higher viscosity fluids
- Unpressurised systems

Why should it be used?

- Easy to retro-fit
- Exceptional communication & 4000 test memory
- Reliable & accurate performance

Available versions:

- Cabinet version
- Plate version

Hydraulic Hoses (External)

Customer to source their own

Re-calibration

Defined by customer Quality Controls recommended 1 year



Open Cabinet version
Front/Right facing view



Plate version
Front/Right facing view



Open Cabinet version
Front facing view

Technical data

In-Line contamination monitor

ICM with keypad and backlit display and relays

Analysis Range

ISO 4406 Codes 8 to 24
 NAS 1638 Class 2 to 12
 AS4059/ISO 11218 Rev E, Table 1 Size Codes 2-12
 AS4059/ISO 11218 Rev E, Table 2 Size Codes, A: 000 TO 12, B: 00 to 12,
 C: 00 to 12, D: 2 to 12, E: 4-12, F: 7 to 12
 AS4059 Rev G, Table 1 Size Codes 2-12
 AS4059 Rev G, Table 2 Size Codes cpc
 [000 to 12, 00 to 12, 00 to 12, 2 to 12, 4 to 12, 7 to 12]
 GBT14039 Codes 8-24
 GJB420B Size Codes, A: 000 to 12, B: 00 to 12, C: 00 to 12,
 D: 2 to 12, E: 4-12, F: 7 to 12
 Please Note: Lower Limits are Test Volume dependent
 GOST 17216

Fluid Compatibility / Corrosion Resistance

Hydrocarbon based & Synthetic hydraulic fluids

Circuit Flow Rate

40 to 400 ml/min (0.01 to 0.1 gpm/min)

Viscosity range

Minimum: 10 cSt
 Maximum: 1000 cSt

Communication Options

PLC compatible. RS485, 4-20mA & CanBus (J1939 typical)

Fluid Temperature (Start Up)

Minimum: Viscosity dependant. Not greater than 1000 cSt
 Maximum: +80 °C (+176 °F)

Fluid Temperature (Continuous)

Minimum: Viscosity dependant. Not greater than 1000 cSt
 Maximum: +80 °C (+176 °F)

Ambient Temperature (Start Up)

From -40 °C to +50 °C (from -40 °F to +122 °F)

Inlet Pressure

Minimum: Positive pressure
 Maximum: 50 bar (725 psi) gauge pressure (pump option dependant)

Outlet Pressure

Minimum: Atmosphere (1.013 bar (14.7 psi) at sea level)
 Maximum: 3.0 bar (43.5 psi) (gauge pressure)

Moisture Sensing (RH%)

Available with or without moisture sensor

Weight

21 kg (46.3 lb) cabinet version
 13 kg (28.7 lb) plate version

Environmental protection

IP55

Dimensions

Cabinet version:
 Width 482 mm (19")
 Height 562 mm (22 1/8")
 Depth 226 mm (8 57/64")

Plate version:
 Width 395 mm (15 1/2")
 Height 410 mm (16 9/64")
 Depth 186 mm (7 1/3")

Electric Motor

110V AC Single Phase; 230V AC Single Phase;
 230-400V AC 3 Phase
 400-690V AC 3 Phase

Power Consumption

0.25 kW max

Outer Casing Finish

Cabinet: Powder coated aluminium
 Plate: Stainless steel

Wetted parts

Carbon steel, aluminium, polyamide, C46400 Cu alloy,
 316 stainless steel, PTFE, FR4, Sapphire, FPM

USBi Comms Junction Box

See USBi user guide - cabinet version
 No junction box - plate version
 Industry 4.0 ready with appropriate accessory product

Software

CMP View Software (included)

ACMU is supplied with a full software package and digital product information

Scope of supply

- 1 x ACMU (Specific model will be as per ordered item, 1/4" BSP inlet/outlet ports as standard)
- 1 x 3m Twisted Pair Cable Assembly (Plate version)
- 1 x 5m length twisted pair cable and integrated ICMUSBI (Cabinet version)
- 2 x 1/4" BSP to 7/16 JIC coupling
- 1 x Hard copy Quick start/wiring installation guide
- 1 x Hard copy Fluid Condition Handbook
- 1 x Digital copy of user guides/software/drivers
- 2 x Hard copy of calibration certificate

ACMU GENERAL INFORMATION

CMP View Software

Our new CMP View software is used with all MP Filtri CMP devices. When connected to CMP View, MP Filtri CMP devices can transfer results in realtime, or alternatively, historical results can be downloaded from each device's in-built memory.

- Windows compatible
- Included free with CMP Products
- Brand new design, created in-house for ease of use
- Comprehensive functionality
- Can be mastered quickly without the need for formal training
- Key results and data available at-a-glance
- Full adjustment and control of product settings, test times and alarms
- Easy test report generation
- Full trend analysis
- Universal format across our contamination monitoring product range
- Multi-machine monitoring



Type of applications

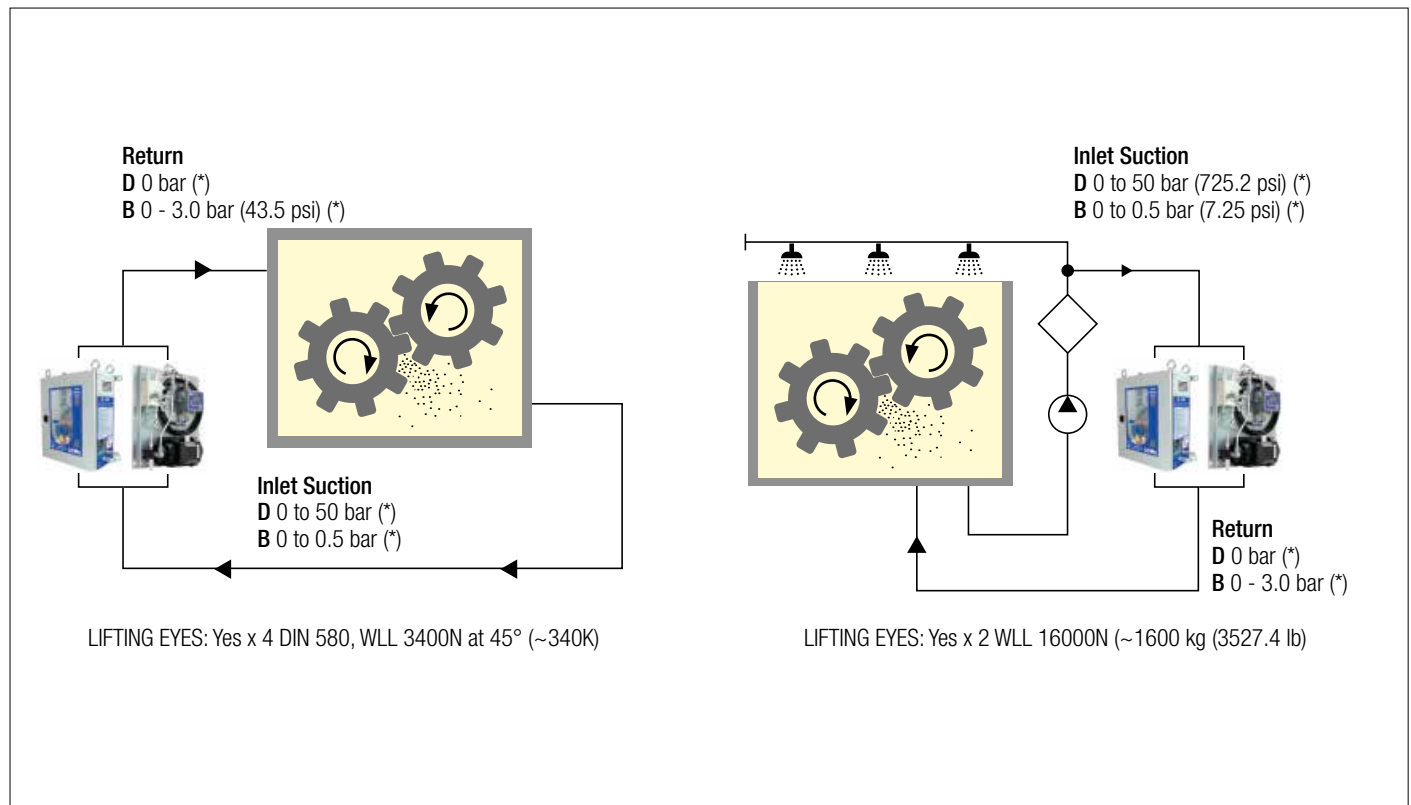

(*) Gauge pressure

ACMU AUXILLIARY CONTAMINATION MONITORING UNIT	
Series	Configuration example: ACMU W D C S 110V
ACMU	Auxilliary Contamination Monitoring Unit
Sensor options: Moisture	
0	Without moisture and temperature sensor
W	With moisture and temperature sensor
Pressure rating	
D	Up to 50 bar inlet (gauge pressure), atmosphere outlet
B	0.5 bar (gauge pressure) {1.0 bar max inlet}, 3.0 bar (gauge pressure) max outlet
Housing type	
C	Cabinet version (supplied with 5 metre communication lead and internal USBi)
P	Plate mounted version
ICM version fitted	
S	Standard ICM*MKRG32.0 installed
1	ICM*MKRG34.0 (Wi-Fi capable)
2	ICM*MKUG32.0 (USB data download)
Voltage	
110V	110V Motor (Dual frequency 50Hz/60Hz, single phase)
230V	230V Motor (single phase)
400V	230-400V Motor (3 phase)
690V	400-690V Motor (3 phase)

Technical data

PLATE VERSION

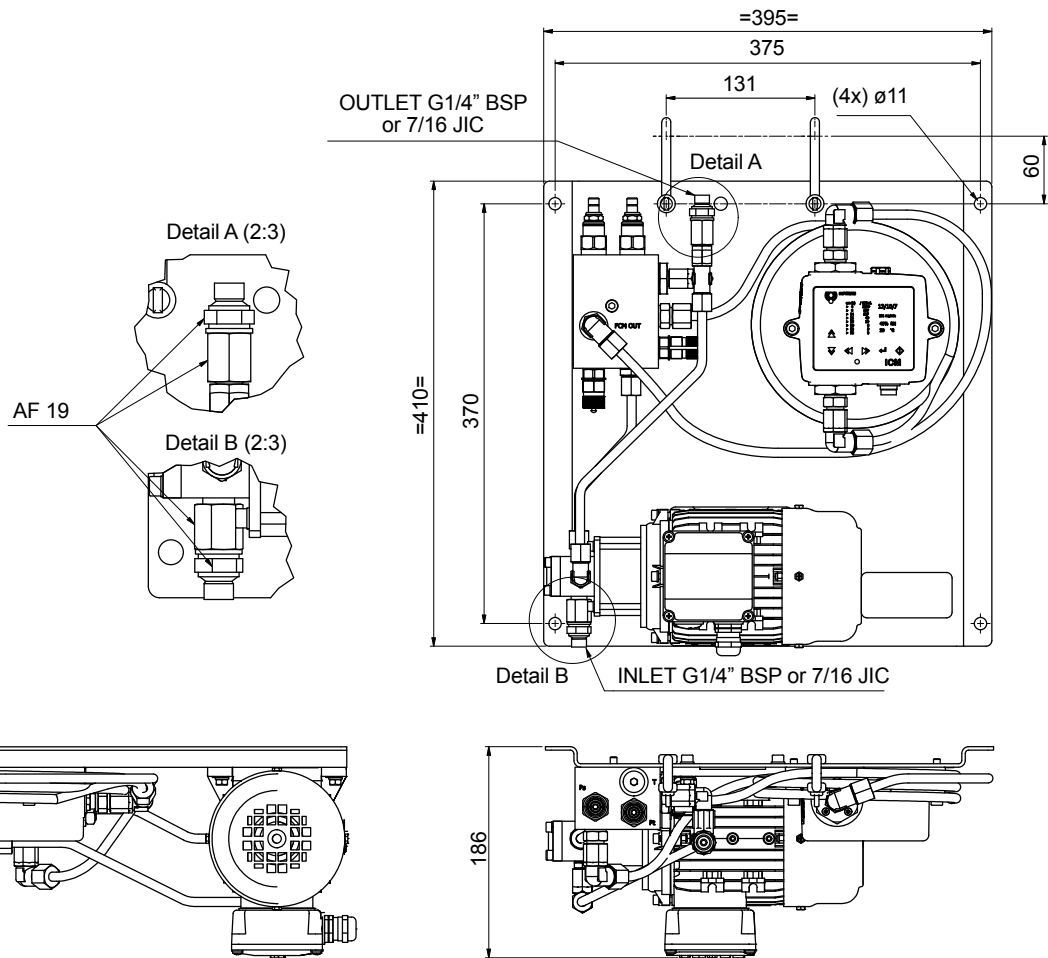

CABINET VERSION

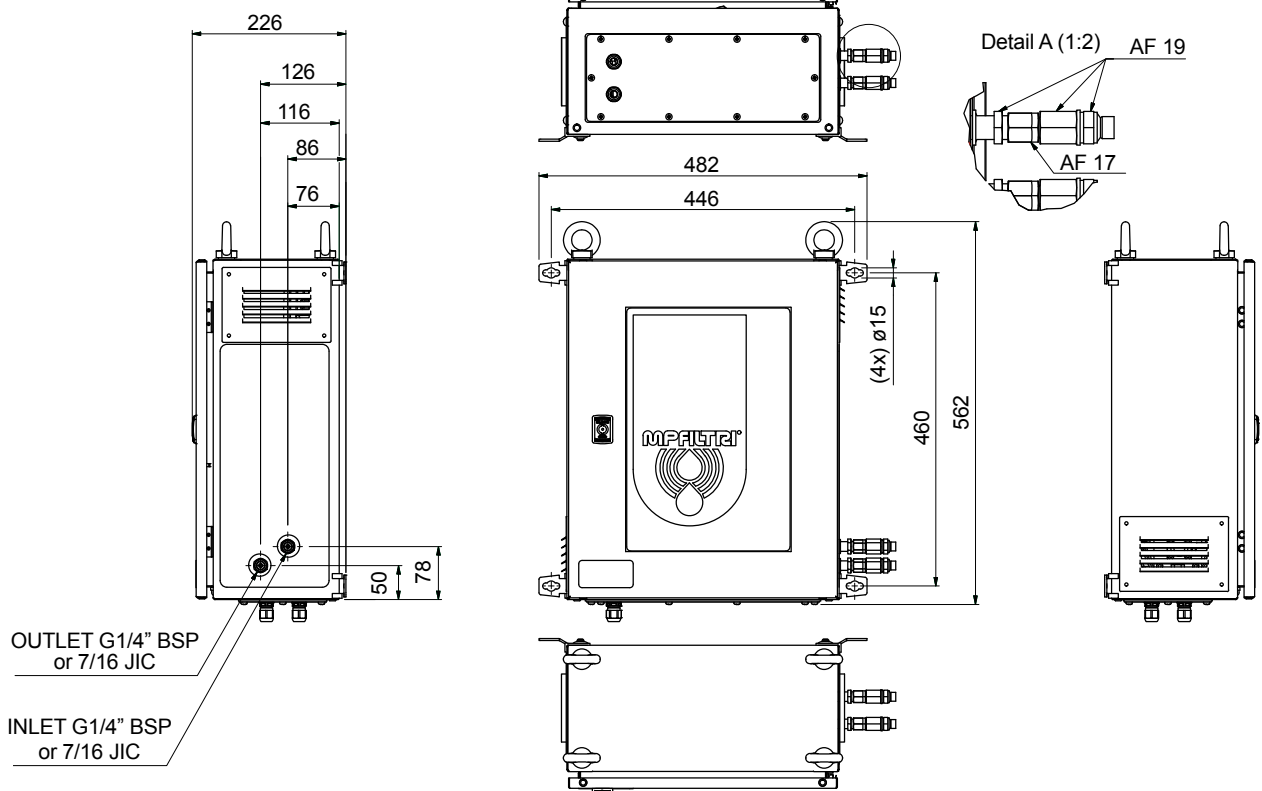

BS110 & BS500

Bottle Samplers - For use with MP Filtri's portable CMP



BS110 GENERAL INFORMATION

Description

Contamination Monitoring Products

Bottle Samplers

The 110 ml bottle samplers are suitable for off-line and laboratory applications where fluid sampling at point of use is inaccessible or impractical.

A fluid de-aeration facility comes as standard.

Features & Benefits

- Vacuum feature for deaeration of fluids
- Compatible with all portable MP Filtri Contamination Monitoring Products
- Strong Laboratory aesthetic
- Transparent outer for visual indication
- Full accessories kit included
- Includes carry case (BS110)
- Contact MP Filtri for use with fluids other than those stated



Front/right facing view



Open case
Front facing view



Front facing view

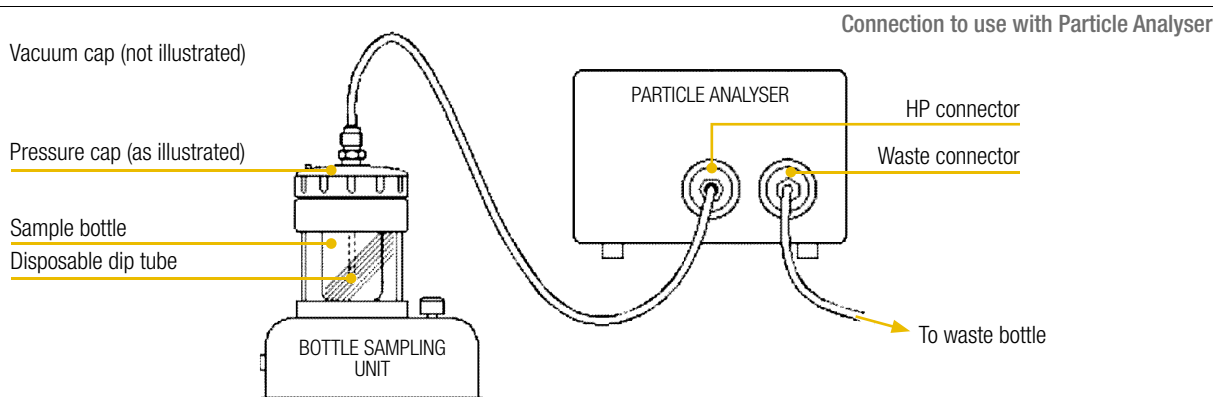

Technical data

Chamber Pressure

Minimum: from 0.61 bar to 0.81 bar / from 8.85 psi to 11.75 psi
 Maximum: 2.5 bar / 36.3 psi only

For use with....

These products can only be used with these portable Contamination Monitoring Products:
 LPA3 M versions
 CML4 M versions

Supply Voltage

12V, 2 amp

On/Off & Stop/Start signals

Switch (Manual Operation)

Hydraulic Hoses (External)

600x2 mm (23 5/8"x5/64") ID M16x2 microbore pressure hose

Flow Rate (ml/min)

Minimum: viscosity dependant
 Maximum: viscosity dependant

Visual Pressure Indicator

No

Viscosity

Minimum: 1 cSt
 Maximum: 400 cSt

Fluid Temperature

Minimum: viscosity dependant
 Maximum: 80 °C (176 °F) continuous

Ambient Temperature

From +10 °C to +55 °C (from 50 °F to +131 °F)

Pressure Gauge

No

Pressure Ranges

2.0 bar / 29 psi options

Outlet Pressure

Minimum: 1013 bar / 14.7 psi
 Maximum: 2.0 bar / 29 psi options

IP Rating

IP50

Fluid Compatibility / Corrosion Resistance

Industrial Hydrocarbon based fluids (typical)

Weight

7 kg (15.4 lb)

Dimensions

Width 130 mm (5 1/8")
 Height 212 mm (8 11/32")
 Depth 163 mm (6 27/64")

Power Consumption

24W

Wetted Parts (Internal)

Aluminium HE30, 303 Stainless Steel, Polyurethane, FPM, Acrylic

Installation

Indoor Use / Laboratory Use

Scope of Supply

- 1 x 110 ml Bottle Sampling unit
- 1 x Pressure cap
- 1 x Vacuum cap
- 1 x M16x2 microbore pressure hose, 600 mm (23 5/8") long
- 1 x 1L waste receptacle
- 1 x hand pump
- 1 x length of hose for hand pump
- 3 x 100 ml clear plastic bottles
- 1 x Digital copy of user guides/software/drivers
- 1 x Carry case

BS110 Bottle Samplers

Dimensions

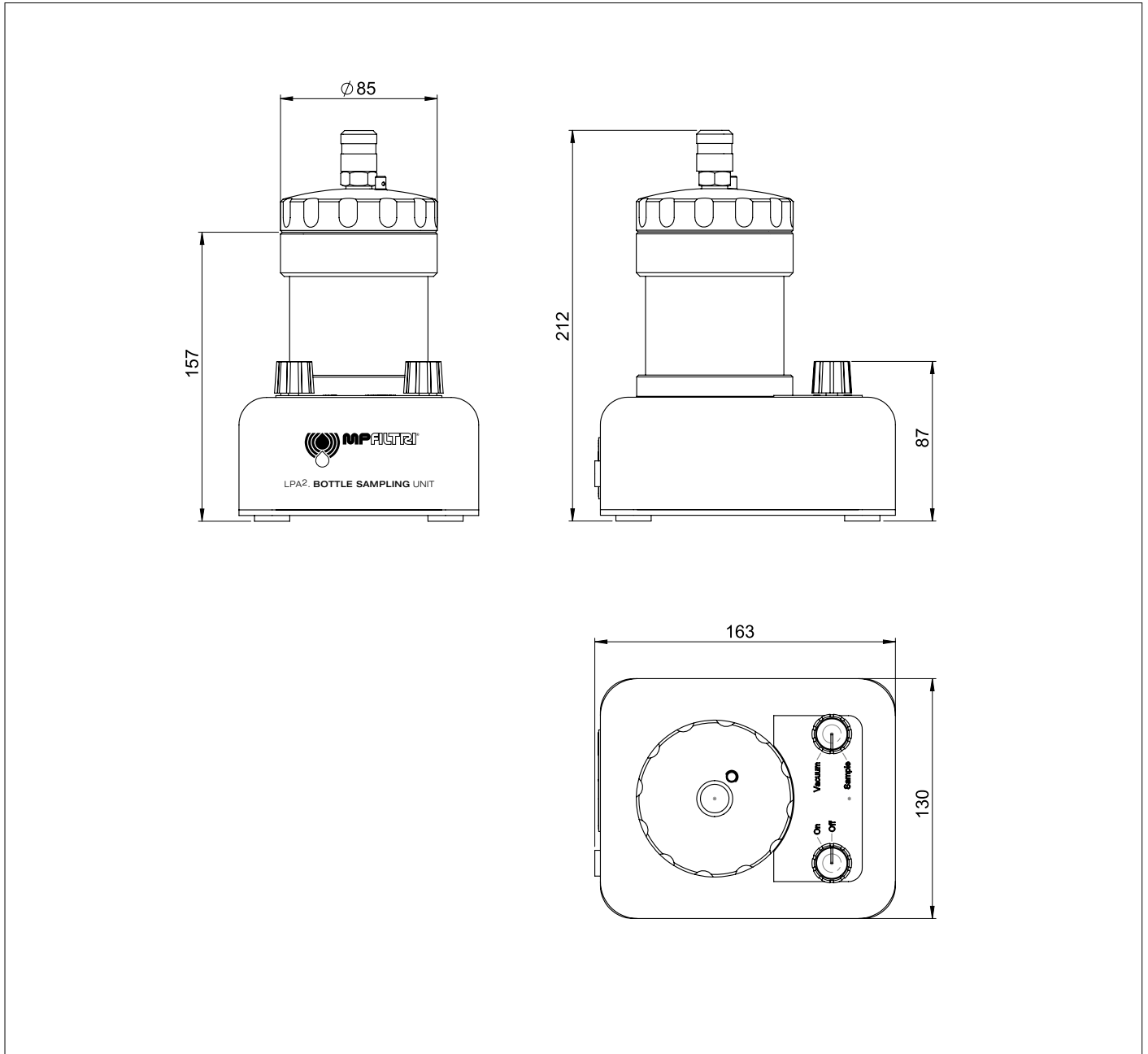

Designation & Ordering code

BOTTLE SAMPLER BS110				
Series	BS110	110 ml fluid volume	Configuration example:	BS110 M 0 0
Fluid compatibility	M	Mineral oil and synthetic fluids		
Pressure rating	0	2.0 bar		
Pressure cylinder option	0	Acrylic cylinder assembly		

BS500 GENERAL INFORMATION

Description

Contamination Monitoring Products

Bottle Samplers

The 500 ml bottle samplers are suitable for off-line and laboratory applications where fluid sampling at point of use is inaccessible or impractical.

A fluid de-aeration facility comes as standard.

Features & Benefits

- Vacuum feature for de-aeration of fluids
- Compatible with all portable MP Filtri Contamination Monitoring Products
- Strong Laboratory aesthetic
- Transparent outer for visual indication
- Full accessories kit included
- Contact MP Filtri for use with fluids other than those stated



Front / Left facing view



Front / Right facing view



Back / Right facing view



Back / Left facing view

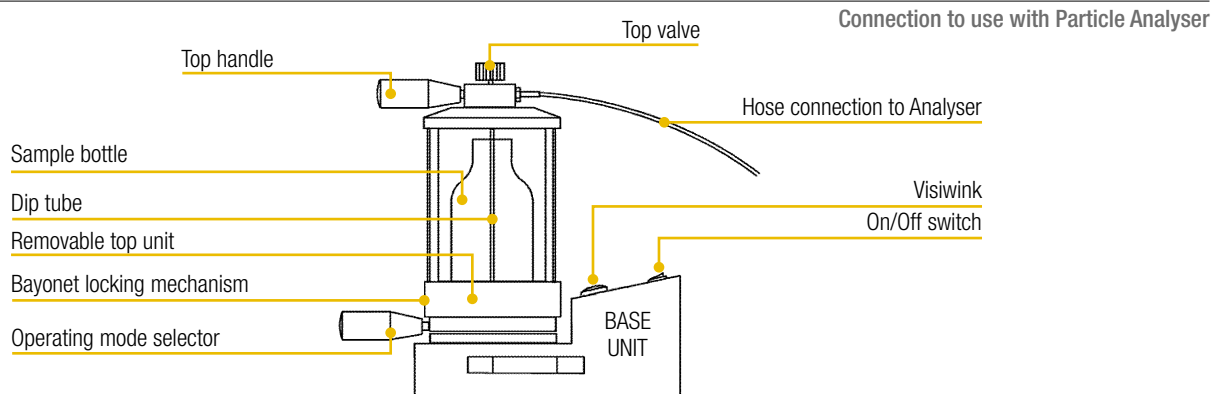

Technical data

Chamber Pressure

Minimum: from 0.61 bar to 0.81 bar / from 8.85 psi to 11.75 psi
 Maximum: 2.5 bar / 36.3 psi (standard), 4.5 bar / 65.3 psi (high pressure)

For use with....

These products can only be used with these portable Contamination Monitoring Products:
 LPA3
 CML4

Supply Voltage

12V, 5 amp

On/Off & Stop/Start signals

Switch (Manual Operation)

Hydraulic Hoses (External)

600x2 mm (23 5/8"x5/64") ID M16x2 microbore pressure hose

Flow Rate (ml/min)

Minimum: viscosity dependant
 Maximum: viscosity dependant

Visual Pressure Indicator

Yes

Viscosity

Minimum: 1 cSt
 Maximum: Not greater than 400cSt (on 2.5 bar version)

Fluid Temperature

Viscosity dependant up to 80 °C (176 °F)

Ambient Temperature

From +10 °C to +55 °C (from 50 °F to +131 °F)

Pressure Gauge

Yes (only on 4.5 bar / 65.3 psi version)

Pressure Ranges

4.5 bar / 65.3 psi or 2.5 bar / 36.3 psi options

Outlet Pressure

Minimum: 1013 bar / 14.7 psi
 Maximum: Version dependant: 2.5 bar / 36.3 psi for O version
 4.5 bar / 65.3 psi for H version

IP Rating

IP50

Fluid Compatibility / Corrosion Resistance

Industrial, aerospace & off-shore control fluids (typical)

Weight

9 kg (19.8 lb)

Dimensions

Width 264 mm (10 25/64")
 Height 340 mm (13.4")
 Depth 350 mm (13.8")

Power Consumption

60W

Wetted Parts (Internal)

Aluminium 6082 T6, 303 Stainless Steel, 316 Stainless Steel.
 Seal & Cylinder material optional

Installation

Indoor Use / Laboratory Use

Scope of Supply

- 1 x 500 ml Bottle Sampling base unit (*)
- 1 x Top cap, pressure/vacuum chamber (*)
- 1 x M16x2 microbore pressure hose, 600 mm (23 5/8") long
- 1 x 19V power adapter; 1 x UK (Type G); 1 x US (Type B); 1 x EU (Type F); 1 x CN/AUS (Type I)
- 3 x 210 ml clear glass bottles
- 2 x 500 ml clear glass bottles (V version only)
- 1 x Digital copy of user guides/software/drivers

(*) Specific model will be as per ordered item

BS500 Bottle Samplers

Dimensions

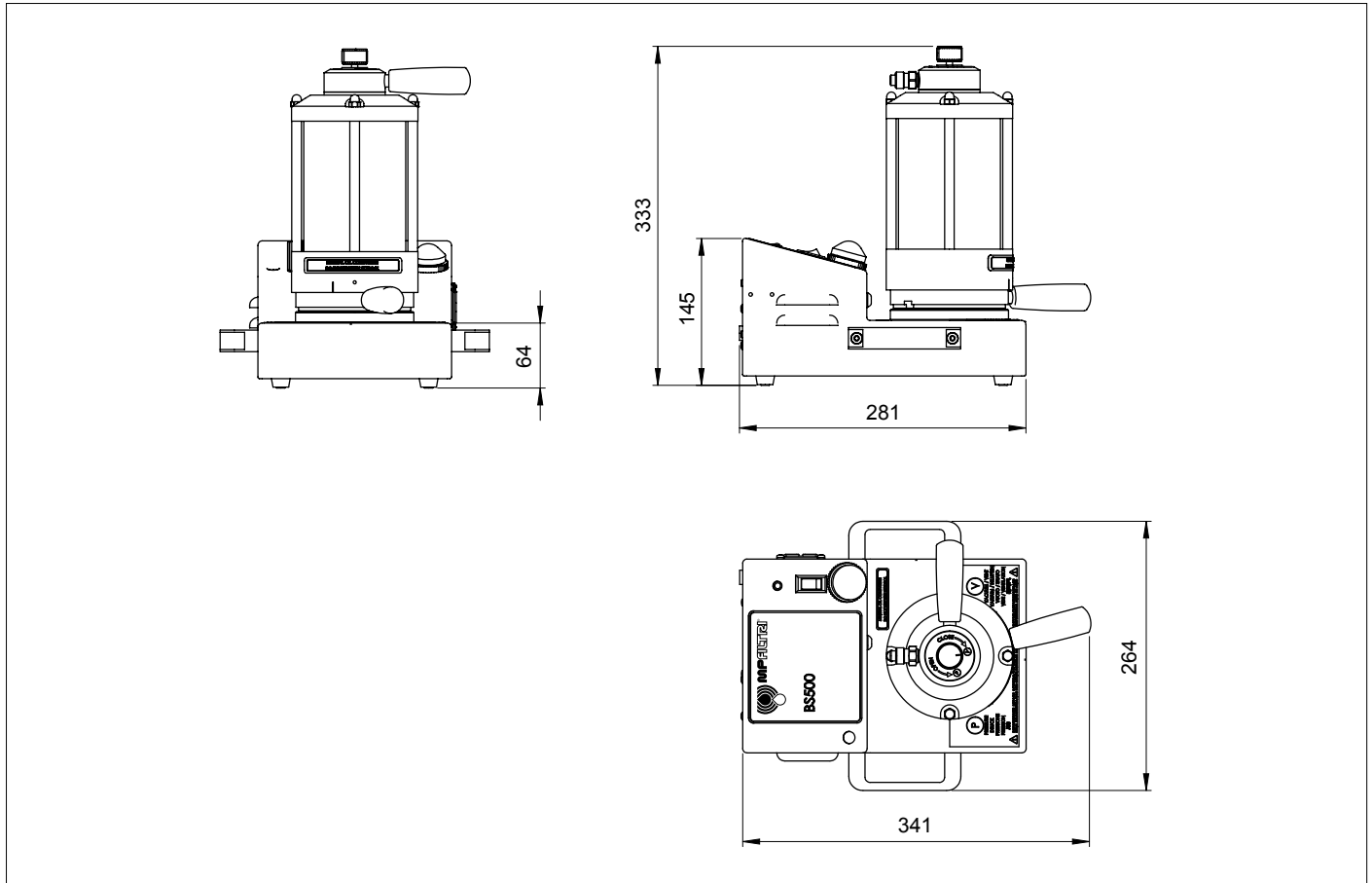

Designation & Ordering code

BOTTLE SAMPLER BS500	
Series	Configuration example: BS500 V 0 0 UK
BS500	500 ml fluid volume
Fluid compatibility	
V	Mineral oil and synthetic fluids, Subsea and water based fluids
E	Phosphate ester and aggressive fluids
S	Phosphate ester and aggressive fluids, Mineral oil and synthetic fluids, Subsea and water based fluids
Pressure rating	
0	2.0 bar, standard option
H	4.0 bar, high pressure option (*)
Pressure cylinder option	
0	Acrylic cylinder assembly
S	Glass cylinder assembly (**)
Power adapter options	
1	UK (Type G)
2	EU (Type F)
3	US (Type A)
4	AUS/CN (Type I)

(*) = H version only available in BS500 V version

(**) = Glass version only available in BS500 E & S version

FLUID SAMPLING

Bottles



At MP Filtri we offer a range of standard & ultra-clean glass bottles for your sampling needs:

100 ml, 210 ml & 500 ml Standard Bottles (not certified clean)

- 100 ml, available in amber glass or clear plastic varieties
- 210 ml, available in clear glass
- 500 ml, available in clear glass

100 ml & 210 ml Ultra Clean Glass Bottles

- Certified to ISO 3722 Hydraulic fluid power
- Fluid sample containers
- Qualifying and controlling cleaning methods
NAS 0 to NAS 00/ AS4059E Table 1 Class 0

Glass Colour

Clear glass provides better visibility of the sample, making de-aeration easier to monitor. Amber glass may reduce the effect of UV light on the sample, reducing the risk of microbial growth and FAME (fatty acid methyl esters) which can be significant in fuel analysis.

DEAERATION & CLEANLINESS

Samples should be shaken vigorously before use however this causes the sample to become aerated which means leaving it to settle.







The BS500 & BS110 de-aeration facility reduces this settling time, allowing more samples to be analysed thereby increasing productivity.



SAMPLING FACTORS

Below are some of the factors which should be considered when taking a sample. For guidance on sampling procedures refer to ISO 4021 & the product user guide.

- Location of the take-off point
- Homogeneity of the sample
- Local area cleanliness
- Bottle cleanliness
- Equipment cleanliness
- Flushing / Cleaning fluid cleanliness
- Operator clothing & cleanliness
- Air cleanliness

 <p>100 µm Dust particle (dead skin)</p>	 <p>40 µm Pollen</p>	 <p>24 µm White blood cell</p>	 <p>10 µm Dust mite faeces</p>	 <p>8 µm Red blood cell</p>	 <p>3 µm E-coli bacteria</p>
--	--	--	--	---	--

FLUID SAMPLING

Sample pumps

Hand pump



For systems where there is no practical access to a test point, a sample may need to be taken from an un-pressurized reservoir.

For this occurrence we offer a simple **hand pump device** with both off-line sampling products which provides for clean and efficient sampling.

The design ensures that only the hose is in contact with the sample fluid, providing greater confidence in analysis, and we provide a range of adapters to suit our various bottle sizes.

The pump can be fully dismantled for cleaning and the sample hose plus main seal can be replaced to further improve clean practise.

Ultra clean bottles cleaned to and in accordance with DIN/ISO 5884.

Ultra clean bottles cleanliness verified to ISO 3722.

NAS 1638 cleanliness certification of between Class 00 and Class 0.

The pump and its associated parts are also available as a spares. See spares list page 88-89

Descriptions	Part Code	Dimensions (mm)
100 ml - Ultra Clean Bottle (Certified)	P.02	Ø 50x92
100 ml - Standard Bottle Brown Glass	BS0016	Ø 50x91
100 ml - Clear Plastic Bottle	7.111	Ø 51x92
100 ml - Standard Bottle Tray (72 bottles)	BS0072	N/A
210 ml - Ultra Clean Bottle (Certified)	P.03	Ø 65x130
210 ml - Standard Bottle	8.054	Ø 65x122
500 ml - Standard Bottle	8.328	Ø 82x152

How it works

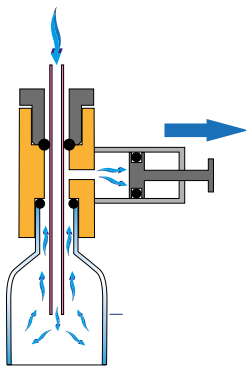

Priming the pump causes a vacuum inside the bottle, syphoning fluid from the reservoir.

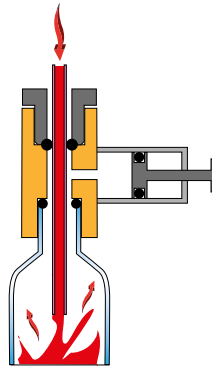

The design of the pump means that only the hose is in contact with the fluid protecting the quality of the sample.

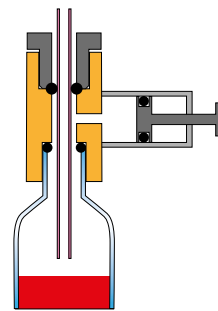

The sample level should always finish below the level of the hose. The bottle can now be removed and capped.

Electric vacuum pump



MP Filtri's Patch Imaging Kit is available with an optional electric pump (spares number: 444.053000). The pump is available with power options for the UK, EU, US, AUS/CN.

PIK - Patch Imaging Kit

Patch Sampling and Digital Imaging Kit



Description

Contamination Monitoring Products

High-resolution microscopic visual analysis of contamination in fluids

Features & Benefits

MP Filtri's new Patch Imaging Kit enables sample-testing of fluids, followed by a full analysis of the contaminants - not only recording and measuring the size and shape of particles under magnification (up to 400x) - but also delivers recording and storage of data and results to your laptop or PC.

Rugged and robust yet perfectly portable, the new Patch Imaging Kit enables fast and accurate testing outside the laboratory.

KEY FEATURES

- High-performance digital microscope, enabling magnification up to 400x
- Sophisticated software enables the measurement and analysis of individual particles
- Full patch testing kit apparatus making it easy to take samples quickly and accurately
- Windows-based software for problem-free installation onto PCs and laptops
- Easy to use without the need for formal training
- Heavy-duty peli-case and laser-cut foam surround for maximum protection and portability
- Simple, step-by-step instructional videos
- Perfectly complements MP Filtri's acclaimed range of portable particle analyser products

KIT COMPOSITION

- Heavy-duty orange pelicase
- Pelicase foam insert
- Self-adhesive patch test covers
- Patch test membranes - 1.2 µm
- Spray bottle
- 2 x Stainless steel tweezers
- Hand-pump
- Waste bottle
- 3 x Clean bottles
- Reusable Nalgene filter assembly
- 0.01 mm Calibration slides
- Microscope power adaptor
- USB Data stick (includes microscope software and PDF manual)
- Hose pouch
- 1 x Hose - 8 x 6 mm Nalgene vacuum cable
- 1 x Hose - 6 x 4 mm Hand pump sampling cable
- Swift Microscope SW150 and accessories including cable and viewer
- Microscope camera - 1.3MP
- Serial plate for patch imaging kit
- A5 document wallet
- Patch test report cards
- Optional Electric Vacuum Pump

PRINCIPAL COMPONENTS TECHNICAL DATA

Microscope:

- Digital microscope that connects direct to PC/laptop
- Fully rotatable monocular head for easy shared use, perfect for laboratories and one-on-one instruction
- Available magnification settings of 40x, 100x and 400x
- A dual-illumination system allows examination of both transparent and solid specimens while cool LED lights protect eyesight
- Sleek design with metal carrying handle and base combine with cordless capability to make this microscope practical for field experiments
- The digital microscope allows operators to examine and easily determine the nature and sizes of solid particles inside the fluid.

PARTICLES QUANTITATIVE ANALYSIS

After determination of the nature (and sizes) of particles inside the fluid, it is useful to quantify the contamination inside system.

Determination of quantitative contamination is done by taking fluid sample from the system (preferably in working conditions) and following the sample fluid analysis with an automated particle analyser or with a portable particle analyser that is linked directly to the system.

They give immediate results according to standard ISO 4406 or NAS 1638. Both particle analysers, portable or not, have values and counter indications. Please note the portable particle analyser need a minimum pressure to work correctly. They produce immediate results.

Technical data

Sampling

Hand pump
Optional Electric Vacuum Pump

Patch test

Patch test membranes -1.2 µm

Digital analysis

Swift Microscope SW150 and accessories including cable and viewer.
Microscope camera - 1.3 Mp
Easy-View software for digital analysis

Samples Filtration System

Reusable Nalgene filter assembly
Waste bottle
3 x Clean bottles
Spray bottle

Accessories for identification and test report

Patch test report cards
0.01 mm Calibration slides
Self-adhesive patch test covers

Rigid carrying case

Heavy-duty orange Pelicase

Weight

12.5 kg (27.5 lb)

Dimensions

Width 519 mm (20 7/16")
Height 265 mm (10 7/16")
Depth 390 mm (15 23/64")



Designation & Ordering code

PIK - PATCH IMAGING KIT

Product	Configuration example:
PIK Patch Imaging Kit	PIK P01
Pump and Electric supply options	
P01 Hand pump only	
P02 Electric Vacuum Pump - UK Plug (Type G)	
P03 Electric Vacuum Pump - EU Plug (Type F)	
P04 Electric Vacuum Pump - US Plug (Type A)	
P05 Electric Vacuum Pump - AUS/CN Plug (Type I)	

Fluid compatibility charts

Fluid compatibility charts

For general fluid compatibility with Contamination Monitoring Products the below rules can be used:

- For mineral oils, synthetic fluids and diesel – the 'M' type variant of unit is recommended.
- For water based/ subsea fluids & 'M' type fluids – the 'N' type variant of unit is recommended.
- For Aerospace phosphate esters, Skydrols® and aggressive fluids along with 'M' & 'N' type fluids- the 'S' type variant is recommended.

All fluids are required to be clear in appearance to allow light to penetrate unhindered.



Scan or click me!

For further and more detailed information on specific fluid compatibility please refer to the fluid compatibility list

Accessories & Spare parts list



Scan or click me!

For further and more detailed information on available accessories and spare parts please refer to the dedicated document.

All data, details and words contained in this publication are provided for use by technically qualified personnel at their discretion, without warranty of any kind.

MP Filtri reserves the right to make modifications to the models and versions of the described products at any time for both technical and/or commercial reasons.

For updated information please visit our website: www.mpfiltri.com

The colors and the pictures of the products are purely indicative.

Any reproduction, partial or total, of this document is strictly forbidden.

All rights are strictly reserved

WORLDWIDE NETWORK

CANADA ♦ CHINA ♦ FRANCE ♦ GERMANY ♦ INDIA ♦ SINGAPORE
UNITED ARAB EMIRATES ♦ UNITED KINGDOM ♦ USA



PASSION  PERFORM

in   



mpfiltri.com
Scan or click me!

MP Filtri reserves the right to make modifications to the models and versions of the described products at any time for both technical and/or commercial reasons.
For updated information please visit our website: www.mpfiltri.com. The colors and the pictures of the products are purely indicative.
Any reproduction, partial or total, of this document is strictly forbidden. All rights are strictly reserved.

MF001000008
EN - 2025.03