

LDP series

Filters featuring filter elements designed according to DIN 24550

Maximum working pressure up to 6 MPa (60 bar) - Flow rate up to 360 l/min

LDP & LDD GENERAL INFORMATION

Filters featuring filter elements designed according to DIN 24550

Descriptions

Low & Medium Pressure filters

Maximum working pressure up to 6 MPa (60 bar)
Flow rate up to 360 l/min

LDP is a range of versatile low pressure filter for transmission, protection of sensitive components in low pressure hydraulic systems and filtration of the coolant into the machine tools.

They are also suitable for the off-line filtration of small reservoirs. They are directly connected to the lines of the system through the hydraulic fittings.

Available features:

- Female threaded connections up to 1 1/2", for a maximum return flow rate of 360 l/min
- Filter element designed in accordance with DIN 24550 regulation
- Fine filtration rating, to get a good cleanliness level into the system
- Water removal elements, to remove the free water from the hydraulic fluid. For further information, see the Contamination Management document and the dedicate leaflet.
- Bypass valve, to relieve excessive pressure drop across the filter media
- Visual, electrical and electronic differential clogging indicators

Common applications:

Delivery lines, in low pressure industrial equipment or mobile machines

LDD is a range of versatile low pressure duplex filter with integrated changeover function to allow the filter element replacement without the system shut-down.

They are directly connected to the lines of the system through the hydraulic fittings.

Available features:

- Female threaded connections up to 1 1/2" and flanged connections up to 1 1/2", for a maximum flow rate of 360 l/min
- Filter element designed in accordance with DIN 24550 regulation
- Fine filtration rating, to get a good cleanliness level into the system
- Water removal elements, to remove the free water from the hydraulic fluid. For further information, see the Contamination Management document and the dedicate leaflet.
- Balancing valve integrated in the changeover lever, to equalize the housing pressure before the switch
- Bypass valve, to relieve excessive pressure drop across the filter media
- Vent ports, to avoid air trapped into the filter going into the system
- Drain ports, to remove the fluid from the housing prior the maintenance work
- Optional sampling ports, to get samples of fluid or to connect additional instrument to the system
- Visual, electrical and electronic differential clogging indicators

Common applications:

- Systems where shut-down causes high costs
- Systems where shut-down causes safety issues

Technical data

Filter housing materials

- Head: Aluminium
- Bowl: Cataphoretic painted steel
- Bypass valve: AISI 304 - Polyamide

Pressure

- Test pressure: 9 MPa (90 bar)
- Burst pressure: 21 MPa (210 bar)
- Pulse pressure fatigue test: 1 000 000 cycles with pressure from 0 to 6 MPa (60 bar)

Bypass valve

- Opening pressure 350 kPa (3.5 bar) ±10%
- Other opening pressures on request.

Δp element type

- Microfibre filter elements - series N: 20 bar
- Fluid flow through the filter element from OUT to IN

Seals

- Standard NBR series A
- Optional FPM series V

Temperature

From -25° C to +110° C

Connections

Inlet/Outlet In-Line

Note

LDP - LDD filters are provided for vertical mounting

Weights [kg] and volumes [dm³]

Filter series	Weights [kg]	Volumes [dm ³]
LDP 016	2.0	1.2
LDP 025	3.0	1.6
LDP 040	5.0	2.2
LDD 016	9.3	3.6
LDD 025	9.5	4.1
LDD 040	11.3	4.8

GENERAL INFORMATION LDP & LDD

Filters featuring filter elements designed according to DIN 24550

Flow rates [l/min]

Filter series	Filter element design - N Series									
	A03	A06	A10	A16	A25	M25	M60	M90	P10	P25
LDP 016	83	91	178	198	222	350	353	358	295	309
LDP 025	124	134	227	245	265	357	358	358	319	330
LDP 040	173	191	274	284	311	359	360	361	332	337
LDD 016	68	73	120	130	140	189	190	192	169	174
LDD 025	93	98	142	149	157	191	192	192	178	181
LDD 040	118	126	161	165	175	192	192	193	182	184

Maximum flow rate for a complete low and medium pressure filter with a pressure drop $\Delta p = 0.7$ bar.

The reference fluid has a kinematic viscosity of 30 mm²/s (cSt) and a density of 0.86 kg/dm³.

For different pressure drop or fluid viscosity we recommend to use our selection software available on www.mpfiltri.com.

You can also calculate the right size using the formulas present on the FILTER SIZING paragraph at the beginning of the full catalogue or at the beginning of the filter family brochure. Please, contact our Sales Department for further additional information.

Hydraulic symbols

Filter series	Execution S	Execution B	Execution S	Execution B
LDP 016	•	•	-	-
LDP 025	•	•	-	-
LDP 040	•	•	-	-
LDD 016	-	-	•	•
LDD 025	-	-	•	•
LDD 040	-	-	•	•

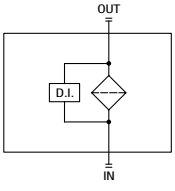
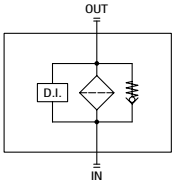
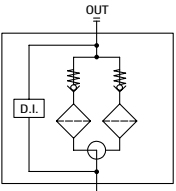
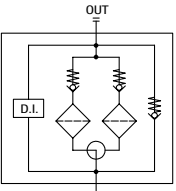
Filter series	Execution S	Execution B	Execution S	Execution B
LDP 016				

Pressure drop

Filter housings Δp pressure drop

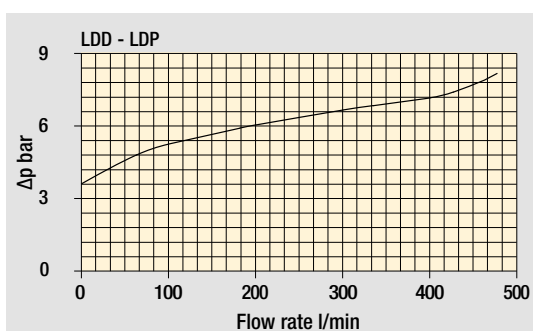
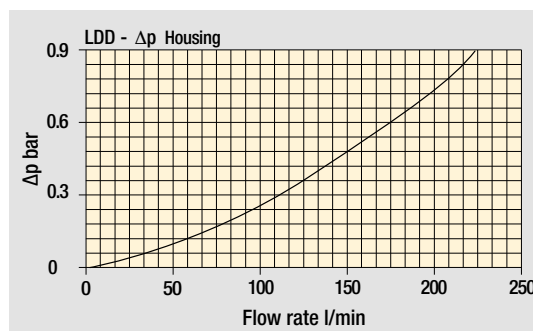
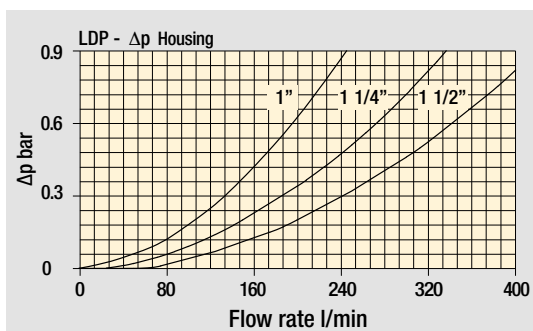

Bypass valve pressure drop

The curves are plotted using mineral oil with density of 0.86 kg/dm³ in compliance with ISO 3968. Δp varies proportionally with density.

Designation & Ordering code

COMPLETE FILTER

Configuration example: **LDP** **025** **B** **A** **D** **6** **A10** **N** **P01**

Series
LDP

Size
016 Element according to DIN 24550 - T3 DN160
025 Element according to DIN 24550 - T3 DN250
040 Element according to DIN 24550 - T3 DN400

Bypass valve
S Without bypass **B** With bypass 3.5 bar

Seals and treatments
A NBR
V FPM

Connections
A G 1" **F** 1 1/2" NPT
B G 1 1/4" **G** SAE 16 - 1 5/16" - 12 UN
C G 1 1/2" **H** SAE 20 - 1 5/8" - 12 UN
D 1" NPT **I** SAE 24 - 1 7/8" - 12 UN
E 1 1/4" NPT

Connection for differential pressure indicator
6 With plugged connection

Filtration rating (filter media)
A03 Inorganic microfiber 3 µm **M25** Wire mesh 25 µm
A06 Inorganic microfiber 6 µm **M60** Wire mesh 60 µm
A10 Inorganic microfiber 10 µm **M90** Wire mesh 90 µm
A16 Inorganic microfiber 16 µm **P10** Resin impregnated paper 10 µm
A25 Inorganic microfiber 25 µm **P25** Resin impregnated paper 25 µm

WA025 Water absorber inorganic microfiber 25 µm

Element Δp
N 20 bar

Execution
P01 MP Filtri standard
Pxx Customized

FILTER ELEMENT

Configuration example: **DN** **025** **A10** **A** **N** **P01**

Element series
DN

Element size
016 Element according to DIN 24550 - T3 DN160
025 Element according to DIN 24550 - T3 DN250
040 Element according to DIN 24550 - T3 DN400

Filtration rating (filter media)
A03 Inorganic microfiber 3 µm **M25** Wire mesh 25 µm
A06 Inorganic microfiber 6 µm **M60** Wire mesh 60 µm
A10 Inorganic microfiber 10 µm **M90** Wire mesh 90 µm
A16 Inorganic microfiber 16 µm **P10** Resin impregnated paper 10 µm
A25 Inorganic microfiber 25 µm **P25** Resin impregnated paper 25 µm

WA025 Water absorber inorganic microfiber 25 µm

Seals and treatments
A NBR
V FPM

Element Δp
N 20 bar

Execution
P01 MP Filtri standard
Pxx Customized

CLOGGING INDICATORS

See page 726

DEA Electrical differential pressure indicator
DEM Electrical differential pressure indicator
DEU Electrical differential pressure indicator
DLA Electrical / visual differential pressure indicator

DLE Electrical / visual differential pressure indicator
DTA Electronic differential pressure indicator
DVA Visual differential pressure indicator
DVM Visual differential pressure indicator

PLUGS

See page 747

T2 Plug

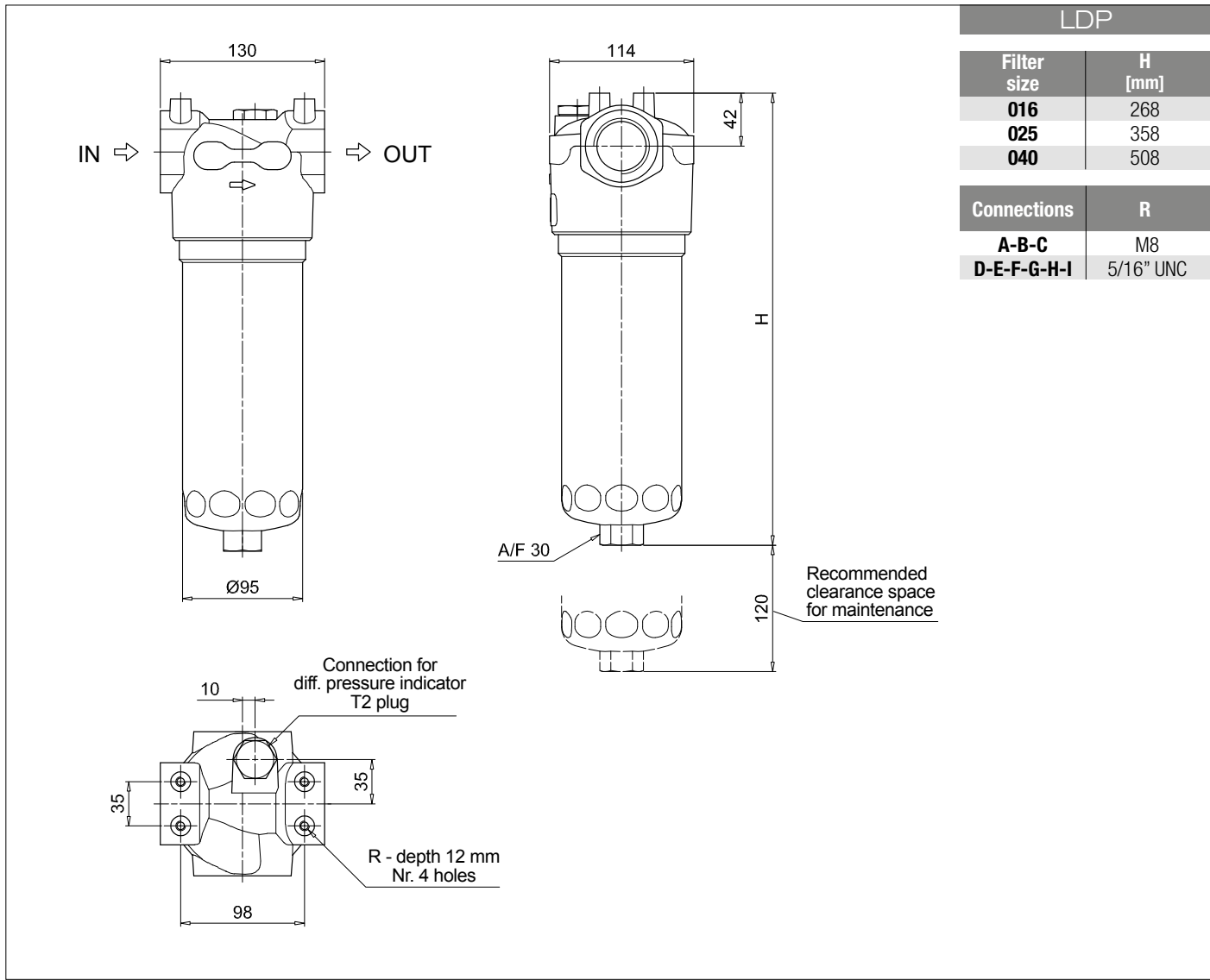

LDP	
Filter size	H [mm]
016	268
025	358
040	508
Connections	R
A-B-C	M8
D-E-F-G-H-I	5/16" UNC

Designation & Ordering code

COMPLETE FILTER

Series **LDD** Configuration example: **LDD 025 B A C 6 A10 N P01**

Size

016 Element according to DIN 24550 - T3 DN160

025 Element according to DIN 24550 - T3 DN250

040 Element according to DIN 24550 - T3 DN400

Bypass valve

S Without bypass **B** With bypass 3.5 bar

Seals and treatments

A NBR

V FPM

Connections

C G 1 1/2"

F 1 1/2" NPT

I SAE 24 - 1 7/8" - 12 UN

L 1 1/2" SAE 3000 psi/M + G 1 1/4"

M 1 1/2" SAE 3000 psi/UNC + 1 1/4" NPT

N 1 1/2" SAE 3000 psi/UNC + SAE 20 - 1 5/8" UN

Connection for differential pressure indicator

6 With plugged connection

Filtration rating (filter media)

A03 Inorganic microfiber 3 µm	M25 Wire mesh 25 µm
A06 Inorganic microfiber 6 µm	M60 Wire mesh 60 µm
A10 Inorganic microfiber 10 µm	M90 Wire mesh 90 µm
A16 Inorganic microfiber 16 µm	P10 Resin impregnated paper 10 µm
A25 Inorganic microfiber 25 µm	P25 Resin impregnated paper 25 µm

WA025 Water absorber inorganic microfiber 25 µm

Element Δp
N 20 bar

Execution
P01 MP Filtri standard
Pxx Customized

FILTER ELEMENT

Element series **DN** Configuration example: **DN 025 A10 A N P01**

Element size

016 Element according to DIN 24550 - T3 DN160

025 Element according to DIN 24550 - T3 DN250

040 Element according to DIN 24550 - T3 DN400

Filtration rating (filter media)

A03 Inorganic microfiber 3 µm	M25 Wire mesh 25 µm
A06 Inorganic microfiber 6 µm	M60 Wire mesh 60 µm
A10 Inorganic microfiber 10 µm	M90 Wire mesh 90 µm
A16 Inorganic microfiber 16 µm	P10 Resin impregnated paper 10 µm
A25 Inorganic microfiber 25 µm	P25 Resin impregnated paper 25 µm

WA025 Water absorber inorganic microfiber 25 µm

Seals and treatments

A NBR

V FPM

Element Δp
N 20 bar

Execution
P01 MP Filtri standard
Pxx Customized

CLOGGING INDICATORS

See page 726

DEA Electrical differential pressure indicator

DEM Electrical differential pressure indicator

DEU Electrical differential pressure indicator

DLA Electrical / visual differential pressure indicator

DLE Electrical / visual differential pressure indicator

DTA Electronic differential pressure indicator

DVA Visual differential pressure indicator

DVM Visual differential pressure indicator

PLUGS

See page 747

T2 Plug

LDD	
Filter size	H [mm]
016	293
025	383
040	533
Connections	R
C	M10
F - I	3/8" UNC
L	M10
M - N	3/8" UNC

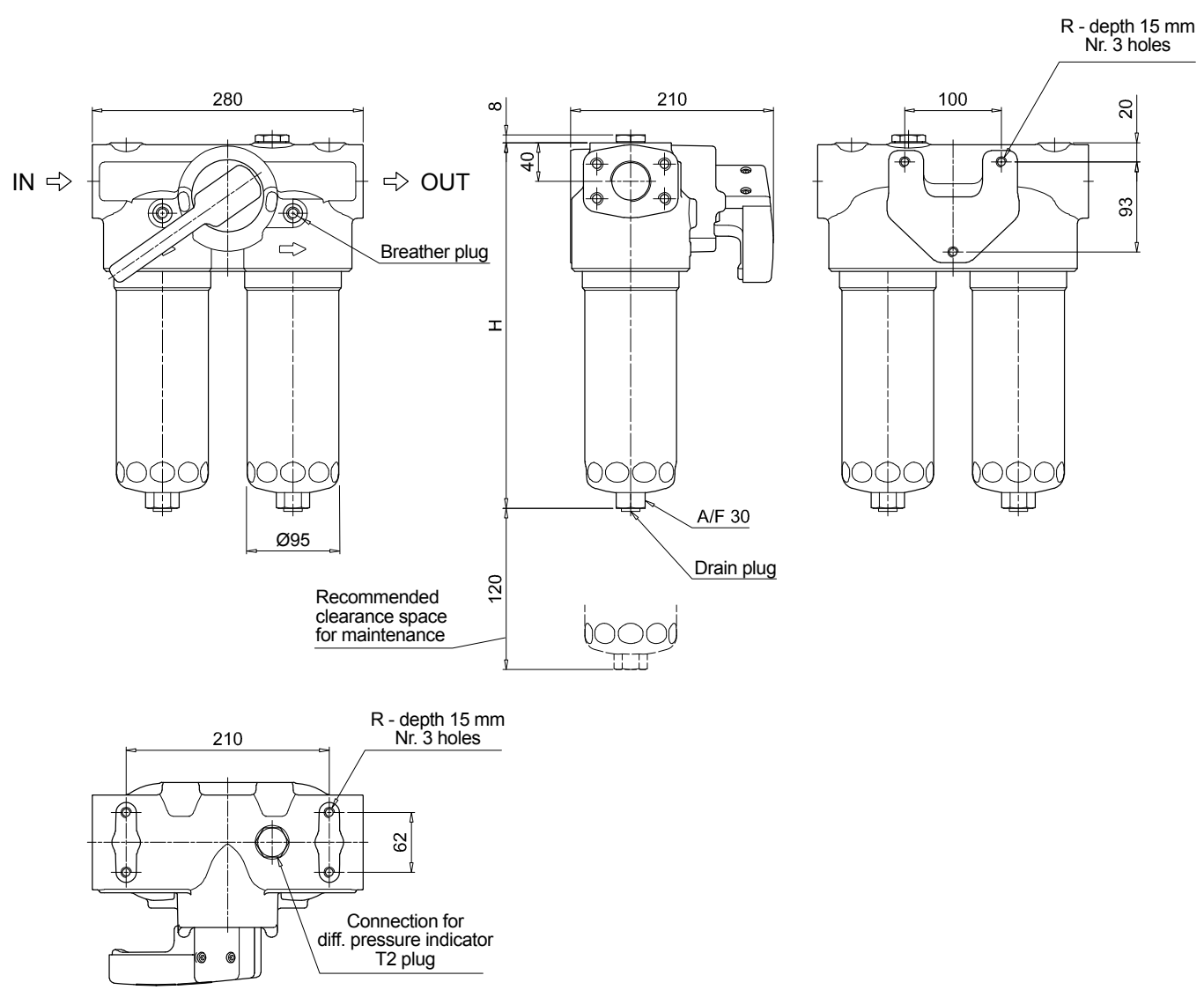

Order number for spare parts

LDP

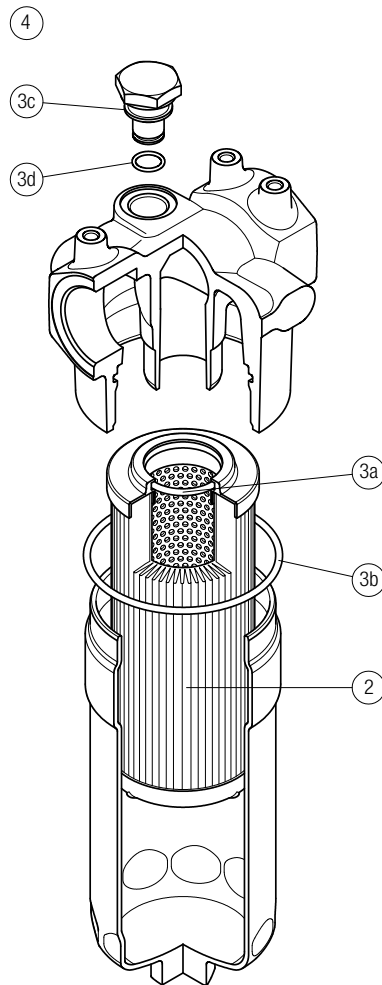

Item:	Q.ty: 1 pc.	Q.ty: 1 pc.		Q.ty: 1 pc.	
Filter series	Filter element	Seal Kit code number		Indicator connection plug	
LDP	See order table	NBR	FPM	NBR	FPM
	2	3 (3a ÷ 3d)		4	
		02050435	02050436	T2H	T2V

Order number for spare parts

LDD

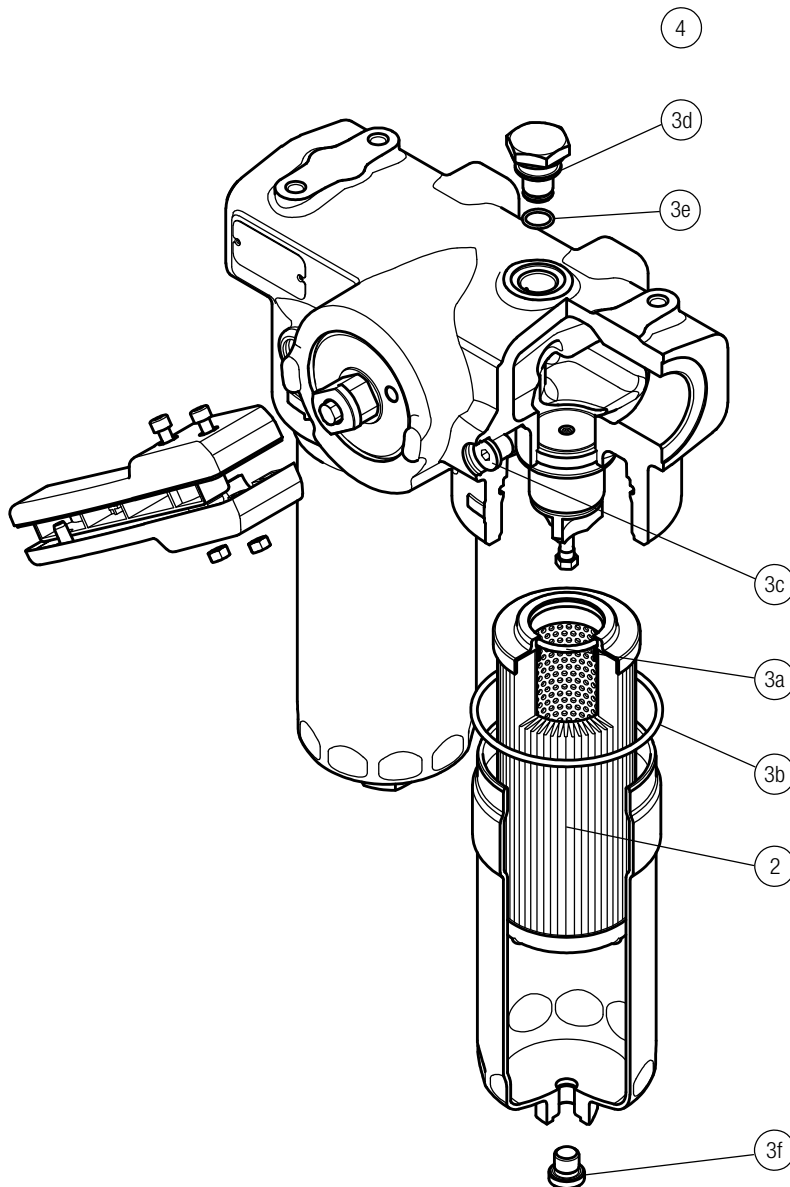

Item:	Q.ty: 1 pc.		Q.ty: 1 pc.		Q.ty: 2 pc.	
Filter series	Filter element	Seal Kit code number		Indicator connection plug		
LDD	See order table	NBR	FPM	NBR	FPM	
	2	3 (3a ÷ 3i)		4		
		02050671	02050672	T2H	T2V	

CLOGGING INDICATORS LOW & MEDIUM PRESS. FILTERS

Designation & Ordering code

DIFFERENTIAL PRESSURE INDICATORS

Series	Configuration example 1:	DE	M	20	H	F	50	P01	
DE Electrical differential pressure indicator	Configuration example 2:	DE	U	50	V	A	50	P01	UL
DL Electrical/Visual differential pressure indicator	Configuration example 3:	DL	E	50	V	A	71	P01	
DT Electronic differential pressure indicator	Configuration example 4:	DT	A	20	H	F	70	P01	
DV Visual differential pressure indicator	Configuration example 5:	DV	M	50	V			P01	

Type	DE	DL	DT	DV
A Standard type	•	•	•	A With automatic reset
M With wired electrical connection	•	-	-	M With manual reset
U Standard type 210 bar, UL certified	•	-	-	S With automatic reset
E For high power supply	-	•	-	
S Compact version	•	-	-	

Pressure setting	DEA	DEM	DEU	DES	DLA	DLE	DTA	DVA	DVM	DVS
12 1.2 bar	•	•	-	•	•	•	•	•	•	•
20 2.0 bar	•	•	•	-	•	•	•	•	•	-
25 2.5 bar	-	-	-	-	-	-	-	-	-	•
40 4.0 bar	-	-	-	•	-	-	-	-	-	•
50 5.0 bar	•	•	•	-	•	•	•	•	•	-

Seals	DEA	DEM	DEU	DES	DL	DT	DVA	DVM	DVS
H HNBR	•	•	-	•	•	•	•	•	•
V FPM	•	•	•	-	•	•	•	•	-

Thermostat	DEA	DEM	DEU	DES	DLA	DLE	DT
A Without thermostat	•	•	•	•	•	•	-
F With thermostat	-	•	-	-	-	•	•

Electrical connections	DEA	DEM	DEU	DES	DLA	DLE	DT
10 Connection AMP Superseal series 1.5	-	•	-	•	-	-	-
20 Connection AMP Timer Junior	-	•	-	-	-	-	-
30 Connection Deutsch DT-04-2-P	-	•	-	•	-	-	-
35 Connection Deutsch DT-04-3-P	-	•	-	-	-	-	-
50 Connection EN 175301-803	•	-	•	-	-	•	-
51 Connection EN 175301-803, transparent base with lamps 24 Vdc	-	-	-	-	•	-	-
52 Connection EN 175301-803, transparent base with lamps 110 Vdc	-	-	-	-	•	-	-
70 Connection IEC 61076-2-101 D (M12)	-	-	-	-	-	-	•
71 Connection IEC 61076-2-101 D (M12), black base with lamps 24 Vdc	-	-	-	-	•	-	-
80 Connection Stud #10-32 UNF	-	-	-	•	-	-	-

Option
P01 MP Filtri standard
Pxx Customized

Certifications	DEU	OTHERS
Without	-	•
UL UL certification	•	-

PLUGS

Series	Configuration example	T2	H
T2 Plug			
T4 Plug			

Seals	T2	T4
A NBR	-	•
H HNBR	•	-
V FPM	•	-